

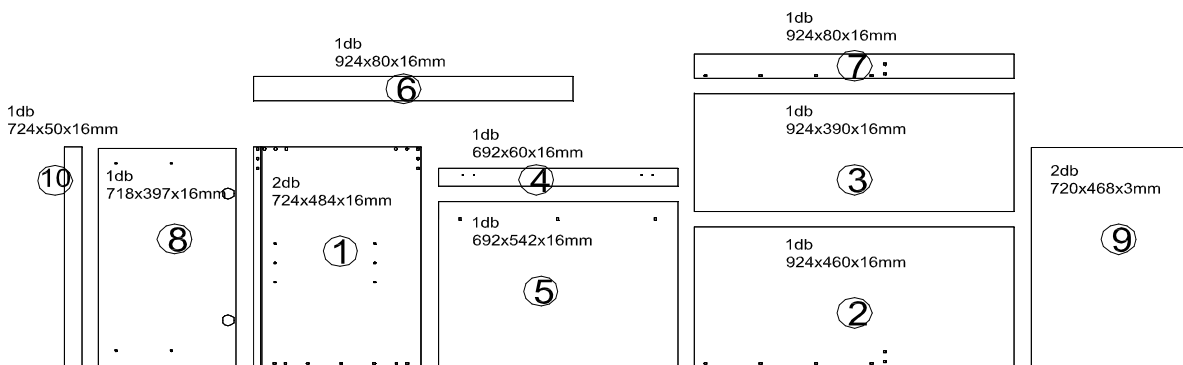

A/100/1A/S

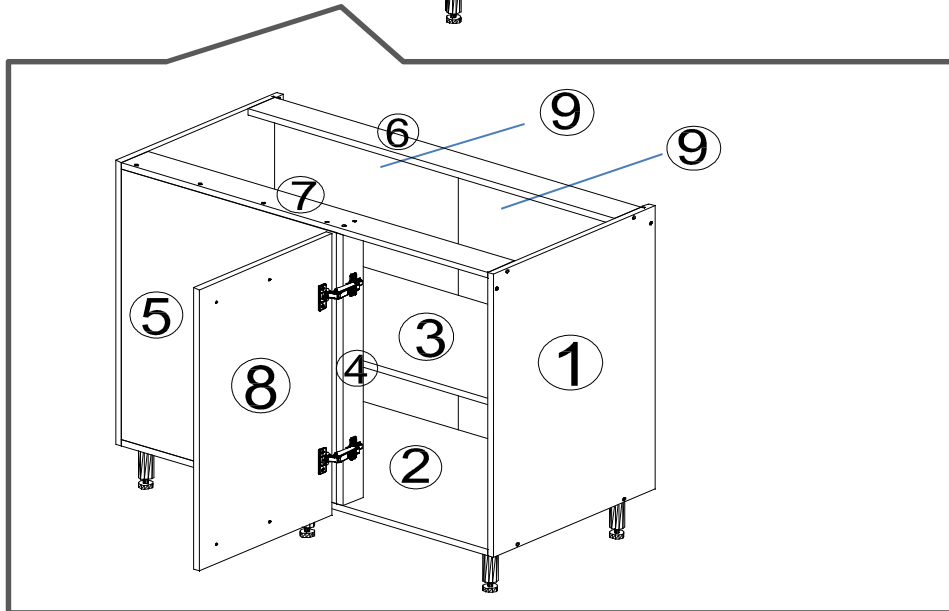
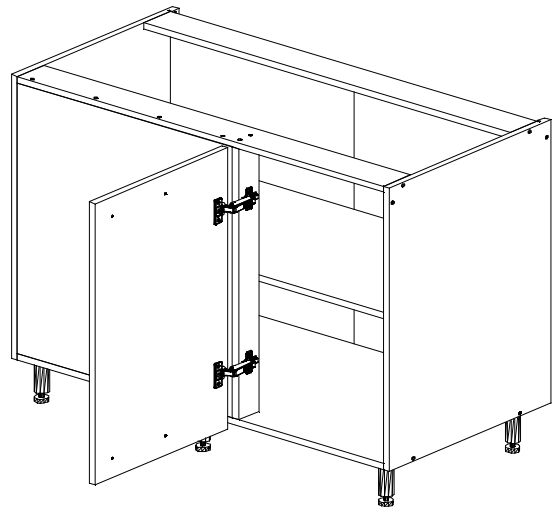
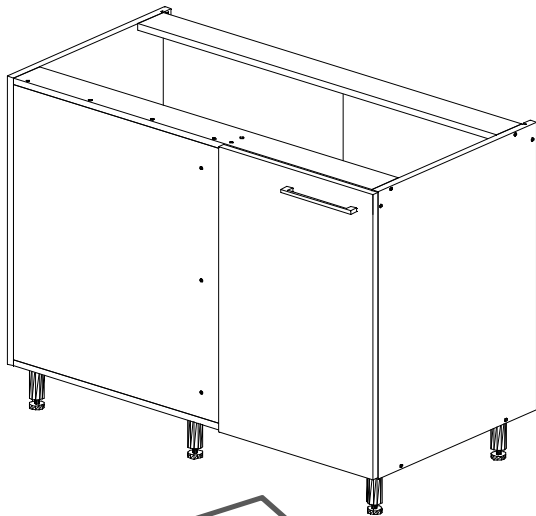

PL 01

1 X



DD 55

6 X



KO 01 8*30

30 X



KN 03 7*50

11 X



PL 12

12 X



PP 01

4 X



PN 01

2 X



PD 01

2 X



UC 11 (160 mm)

1 X



DR 27 3,5*16

32 X



DR 25 4*25

4 X



KV 01 1,5*20

30 X



UC 06 4*30

2 X



KL 01 4 mm

1 X



1.

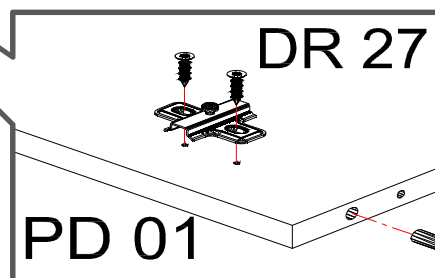
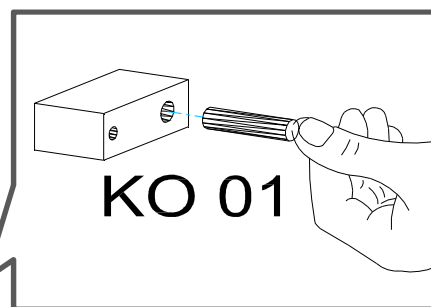
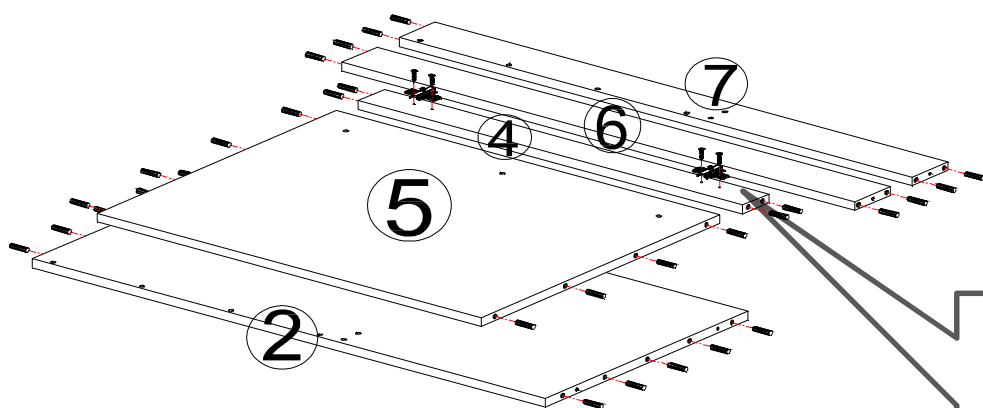

2.

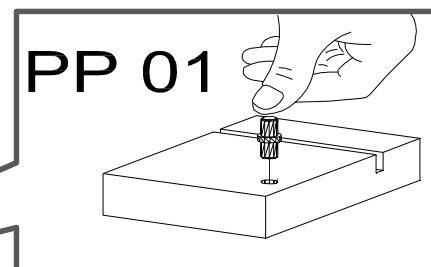
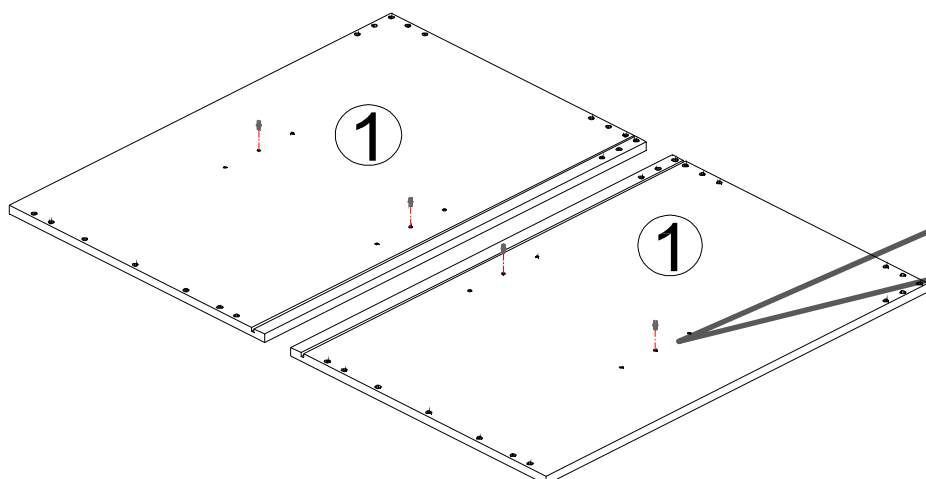

3.

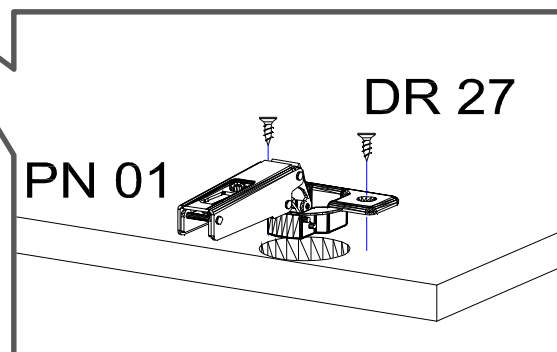
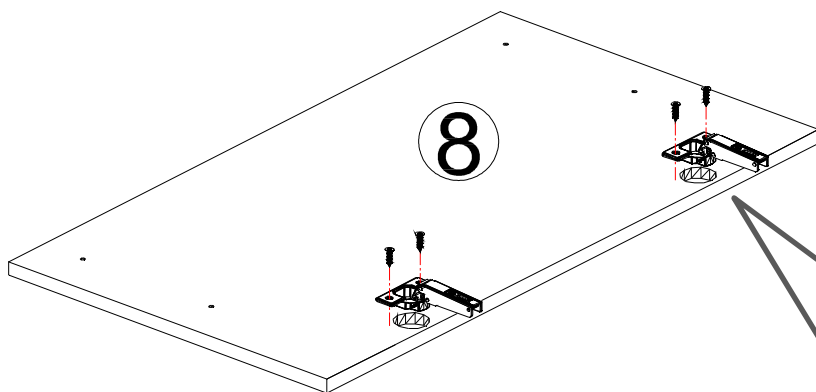

4.

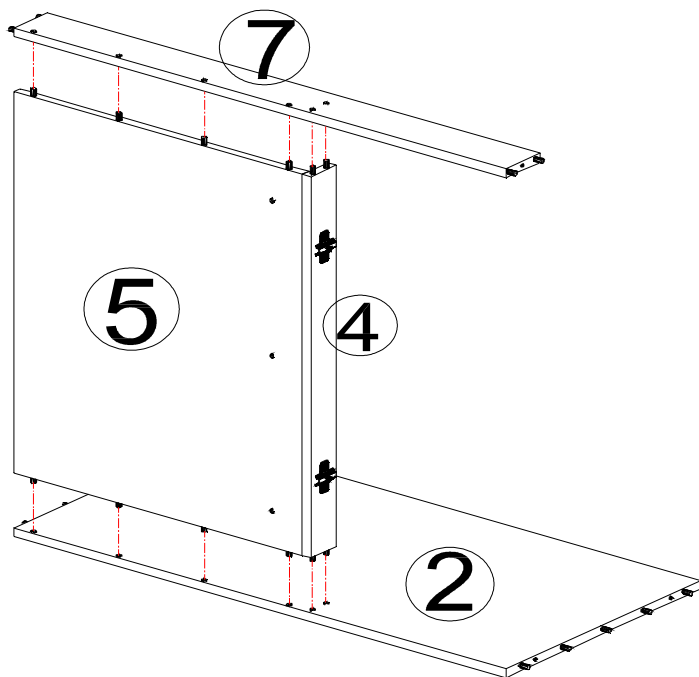

5.

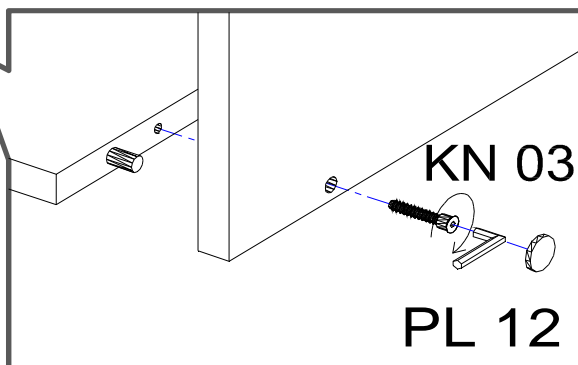
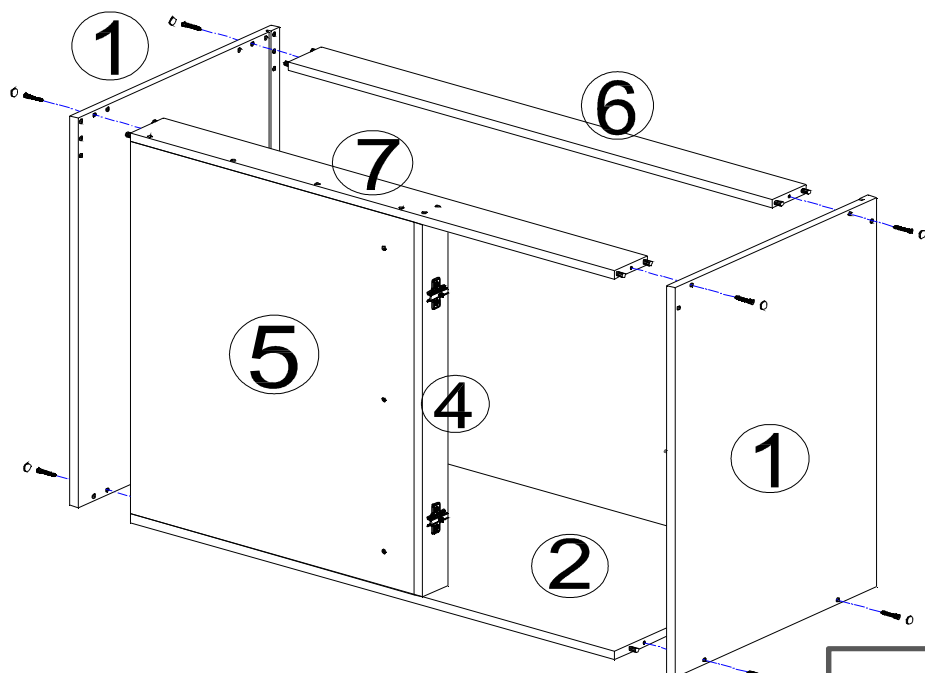

6.

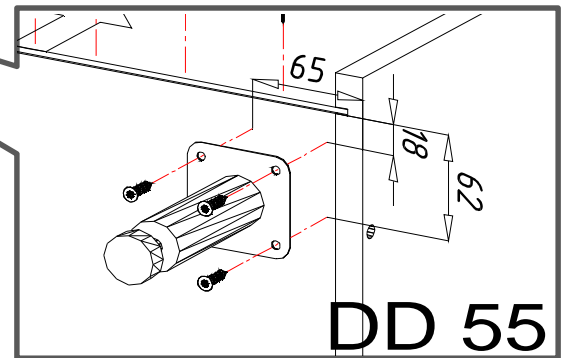
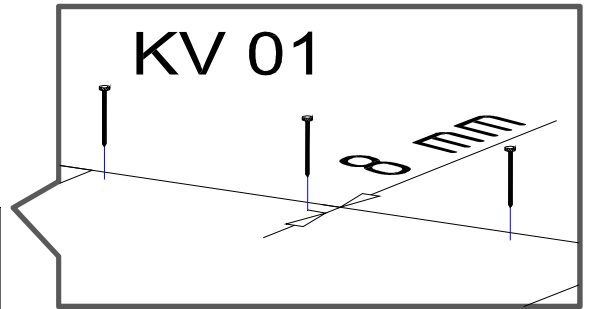
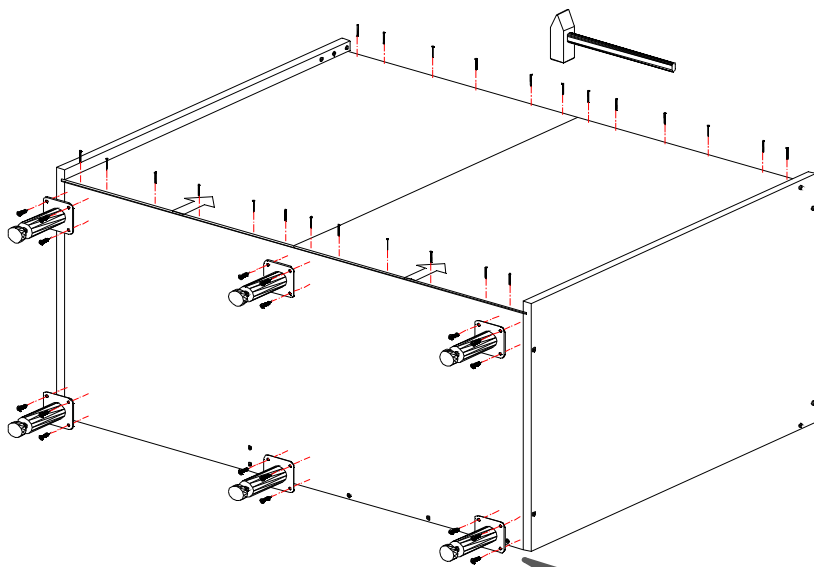

7.

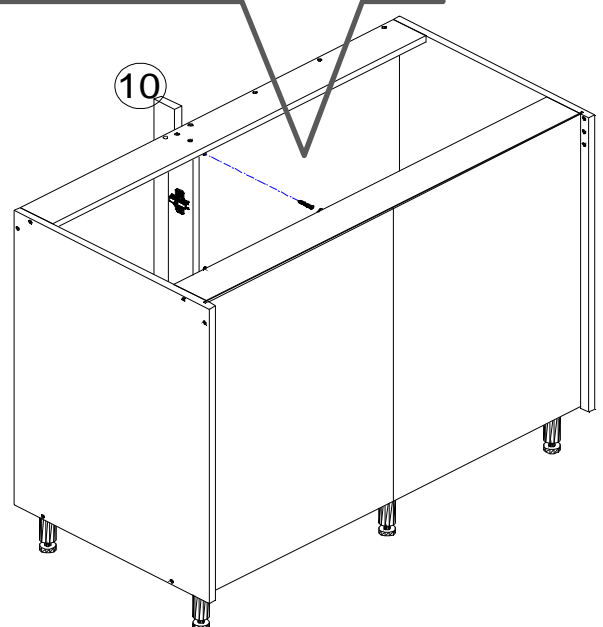
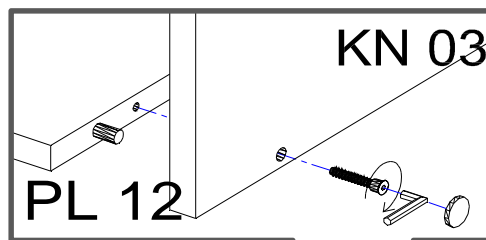
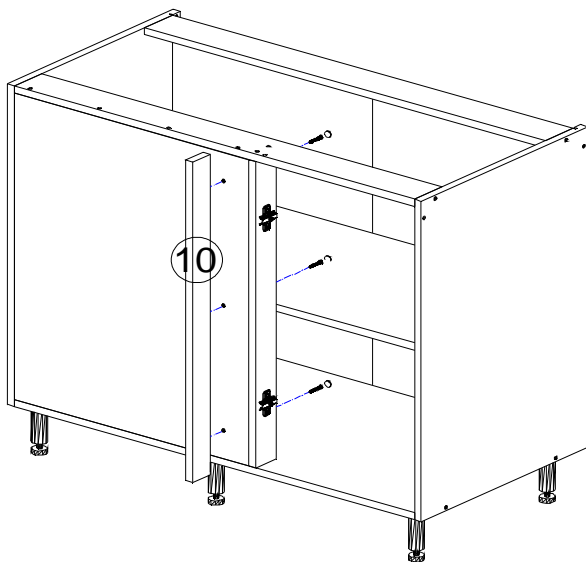

6.

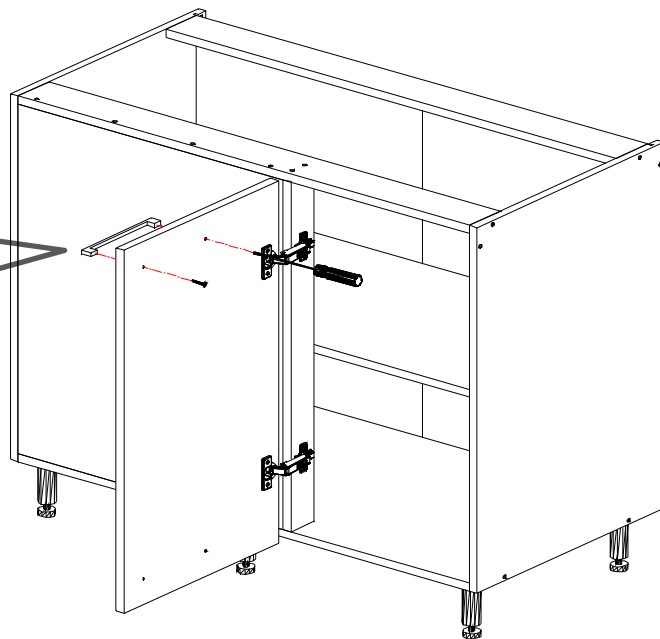
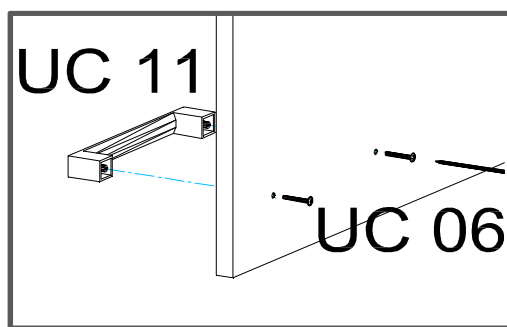

*Az elemek megfelelő stabilitása és baleset megelőzés céljából, az elemeket célszerű egymáshoz rögzíteni egy rejtett pozícióban a (DR 25 4*25) facsavarral!*

