

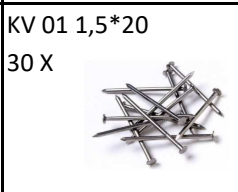

A/60/T

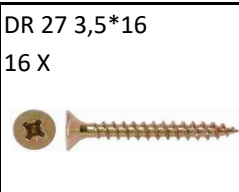

1.

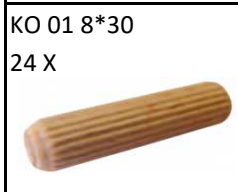
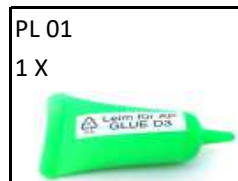
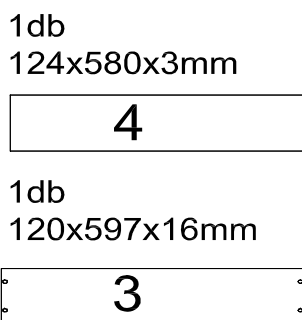
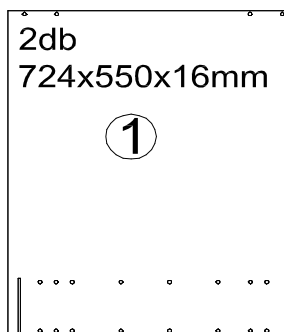
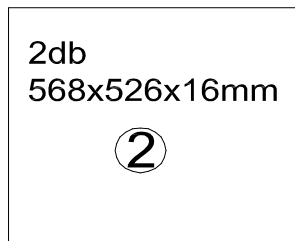
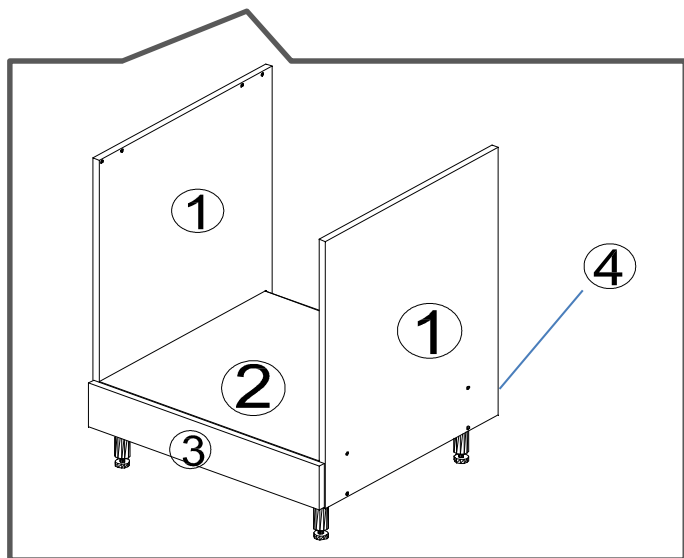
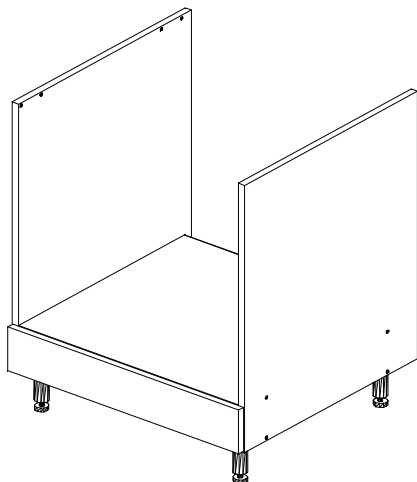
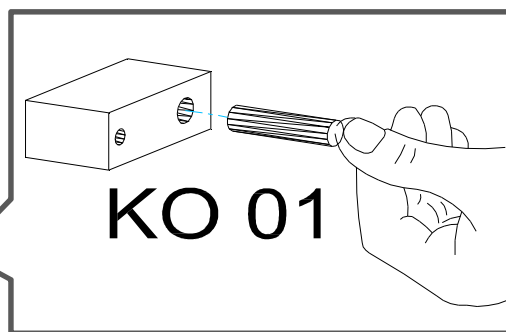
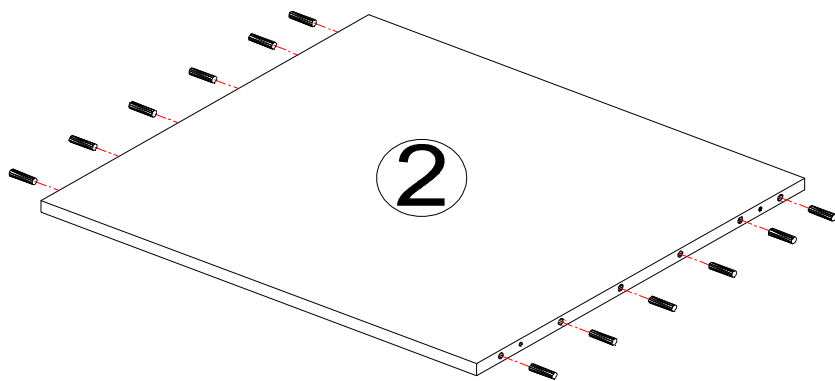

2.

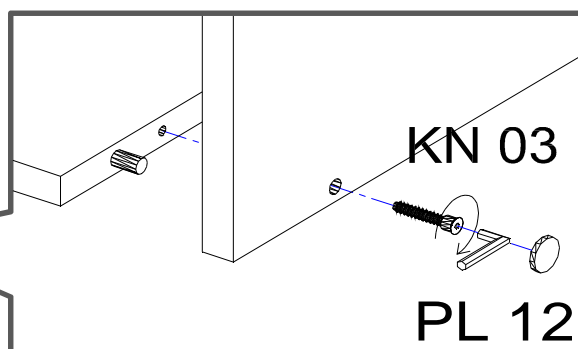
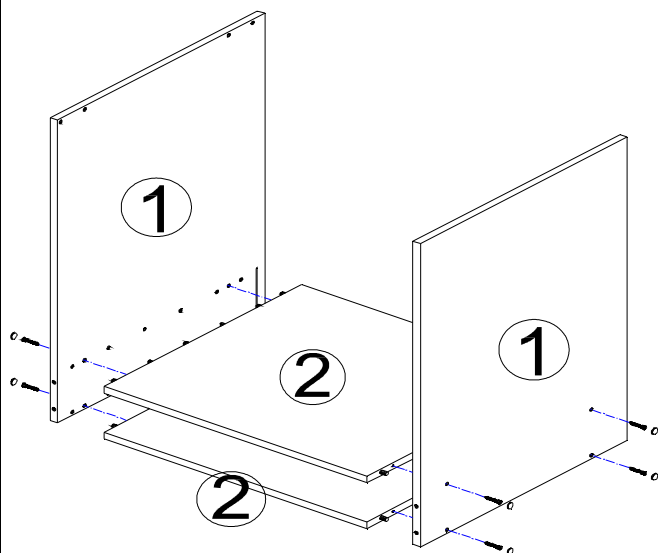

3.

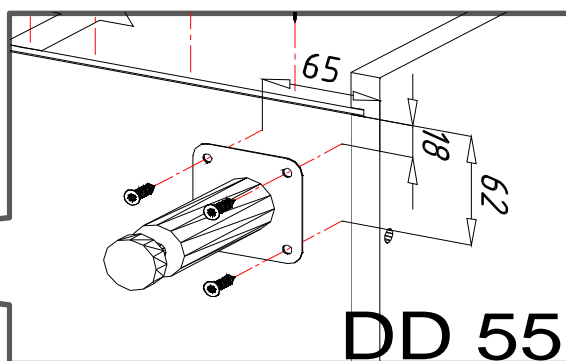
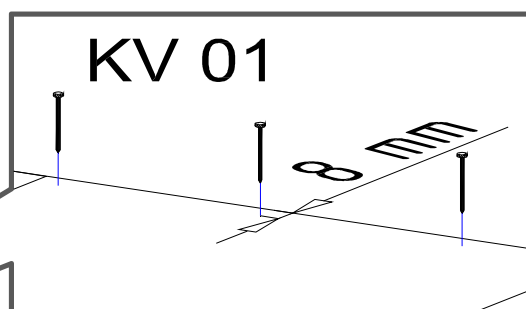
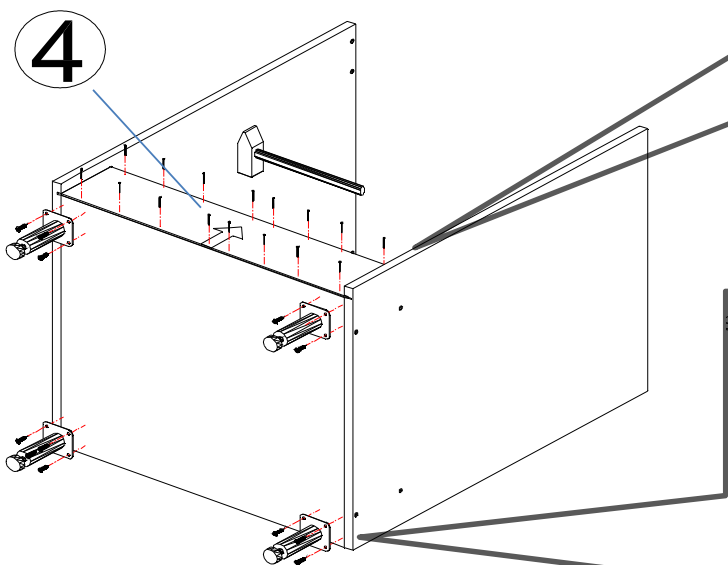

4.

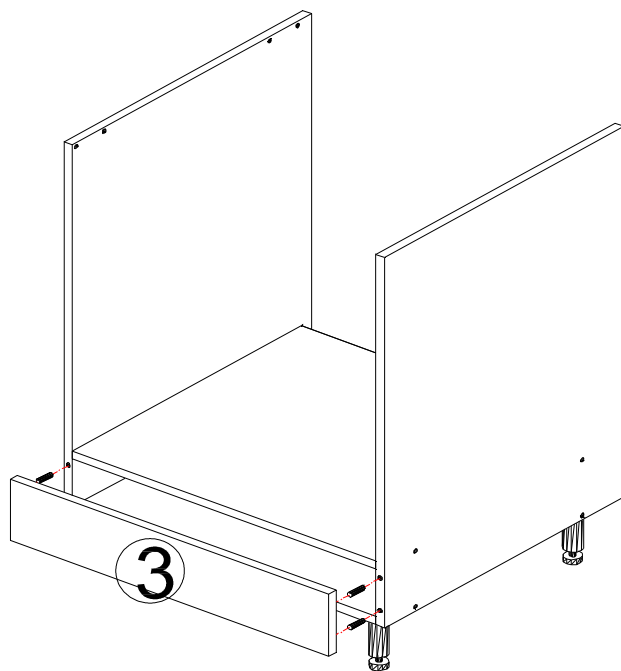

*Az elemek megfelelő stabilitása és baleset megelőzés céljából, az elemeket célszerű egymáshoz rögzíteni egy rejtett pozícióban a (DR 25 4*25) facsavarral!*