

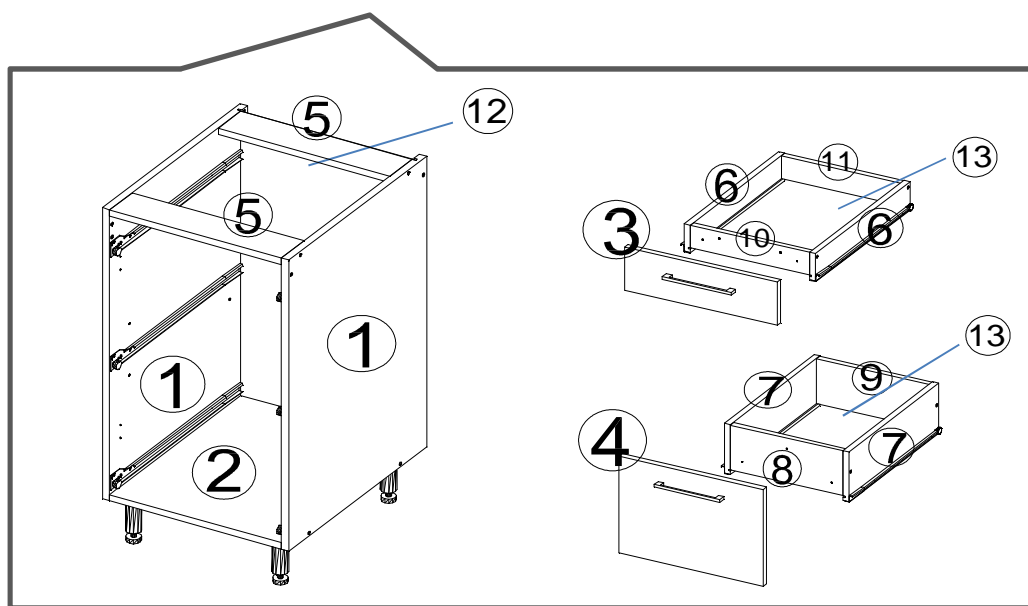

A/40/3F

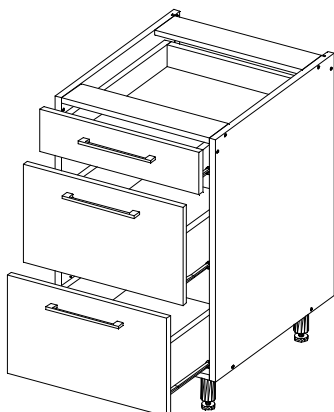

1db
310x65x16mm

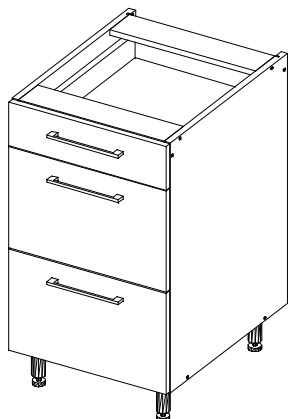
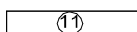

1db
310x65x16mm

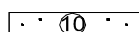

2db
310x135x16mm

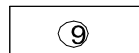

2db
310x135x16mm

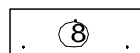

1db
126x397x16mm

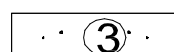

2db
724x484x16mm

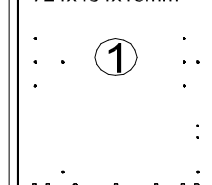

1db
368x80x16mm

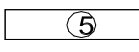

2db
450x80x16mm

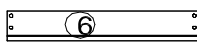

1db
720x380x3mm

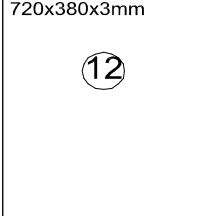

3db
450x383x3mm

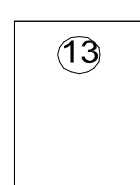

2db
293x397x16mm



1db
368x460x16mm

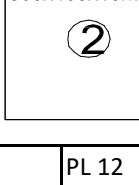

4db
450x150x16mm

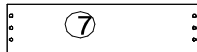

PL 01
1 X



KO 01 8*30
38 X



KN 03 7*50
20X



PL 12
24X



DR 25 4*25
10 X



EU 01 6*11
12 X



VG 03
3 X



UC 11 (160 mm)
3 X



DR 27 3,5*16
16 X



DD 55
4 X



KV 01 1,5*20
30 X



UC 06 4*30/4*40
4 X / 2 X



KL 01 4 mm
1 X



1.

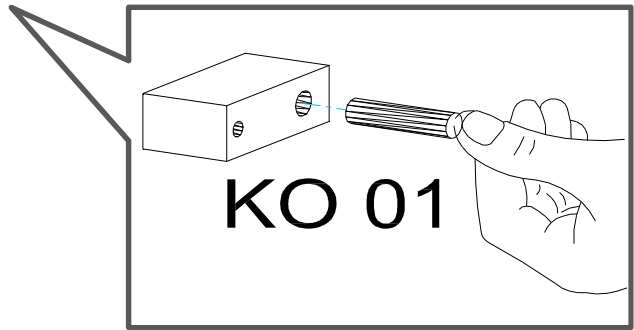
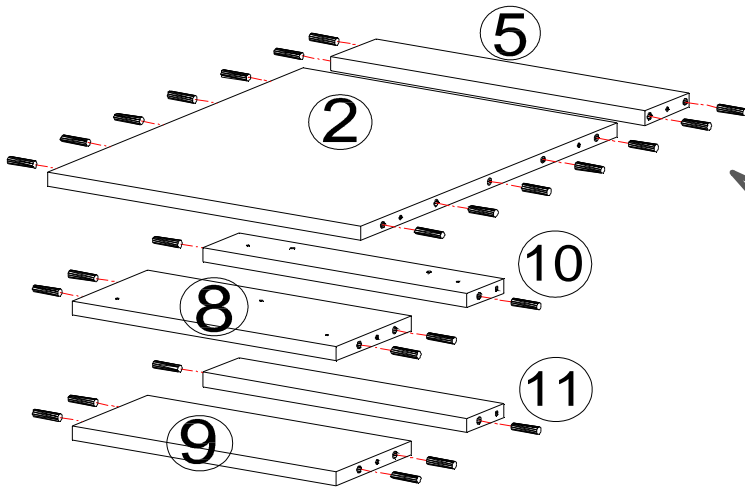

2.

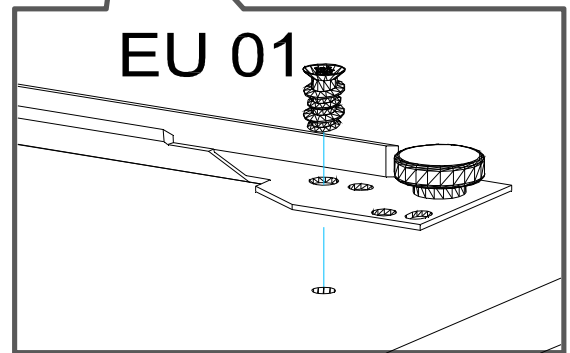
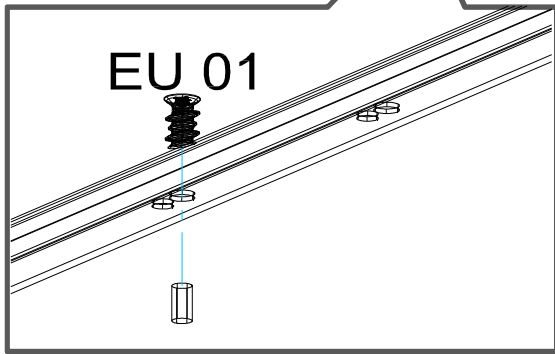
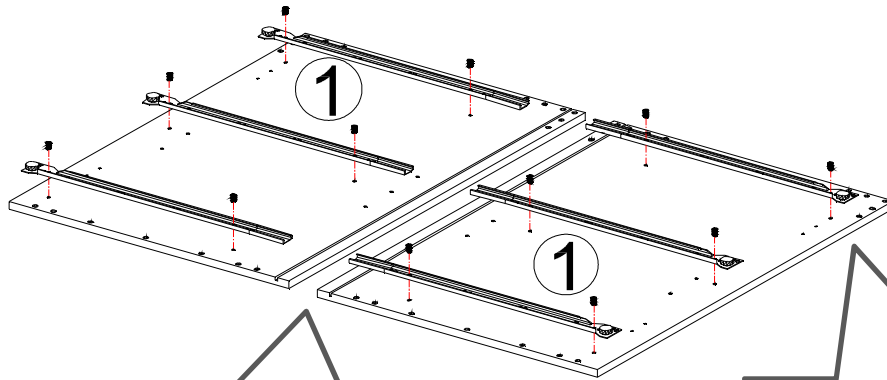

3.

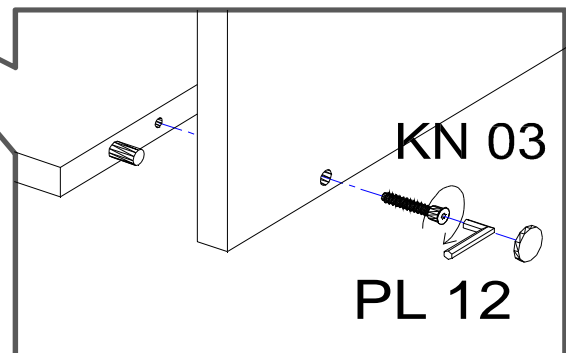
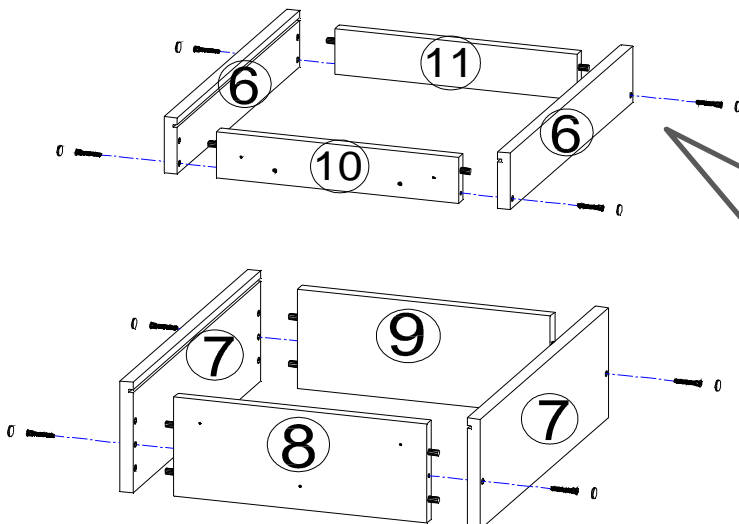

4.

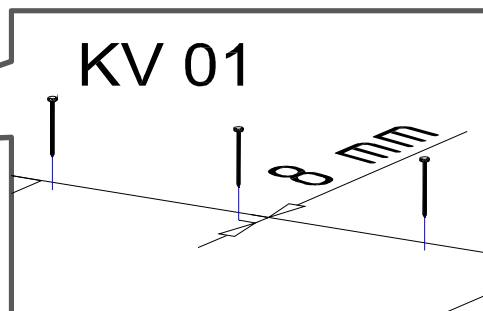
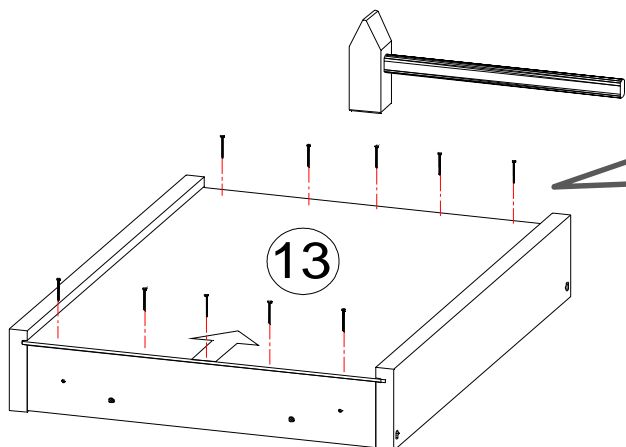

5.

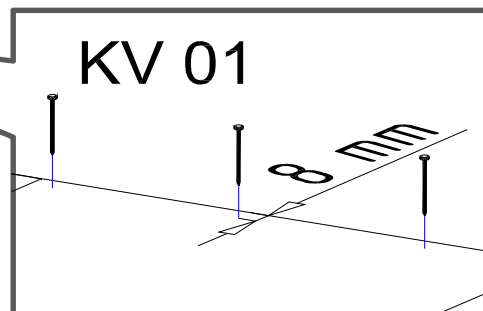
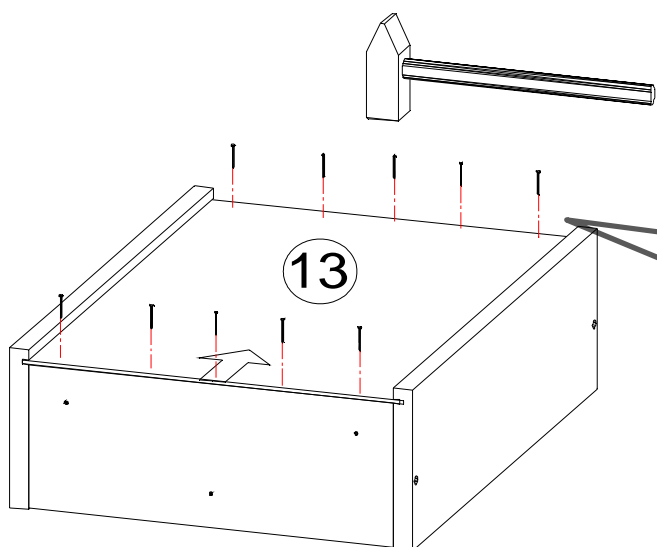

6.

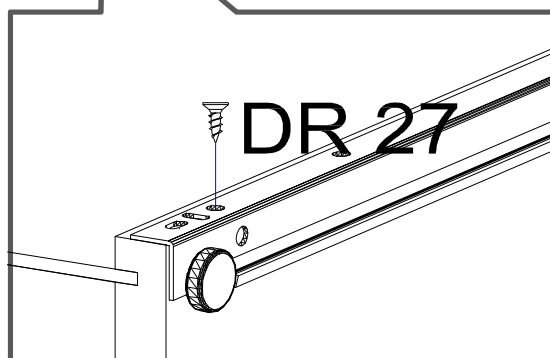
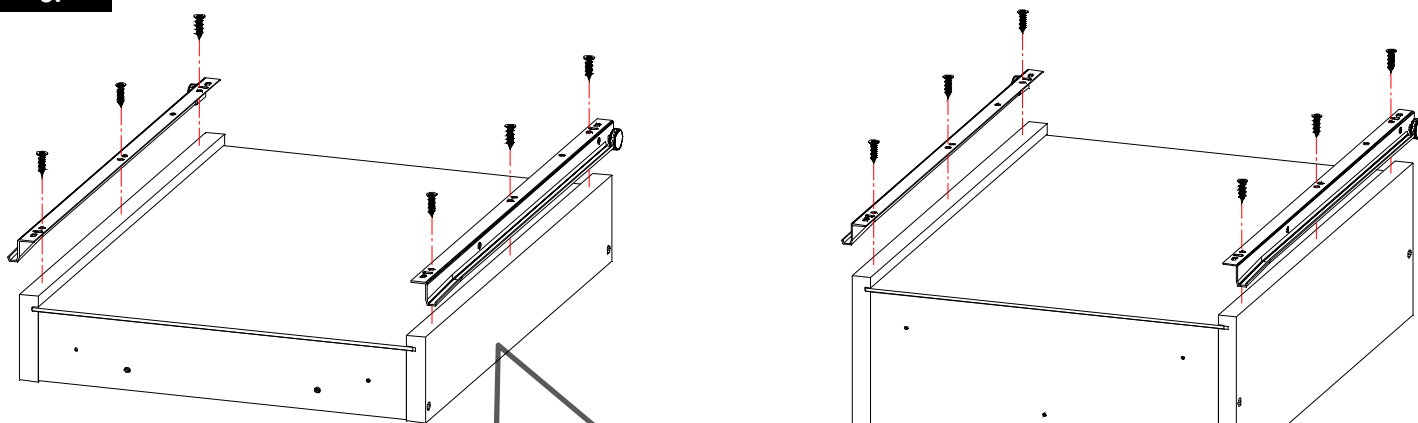

5.

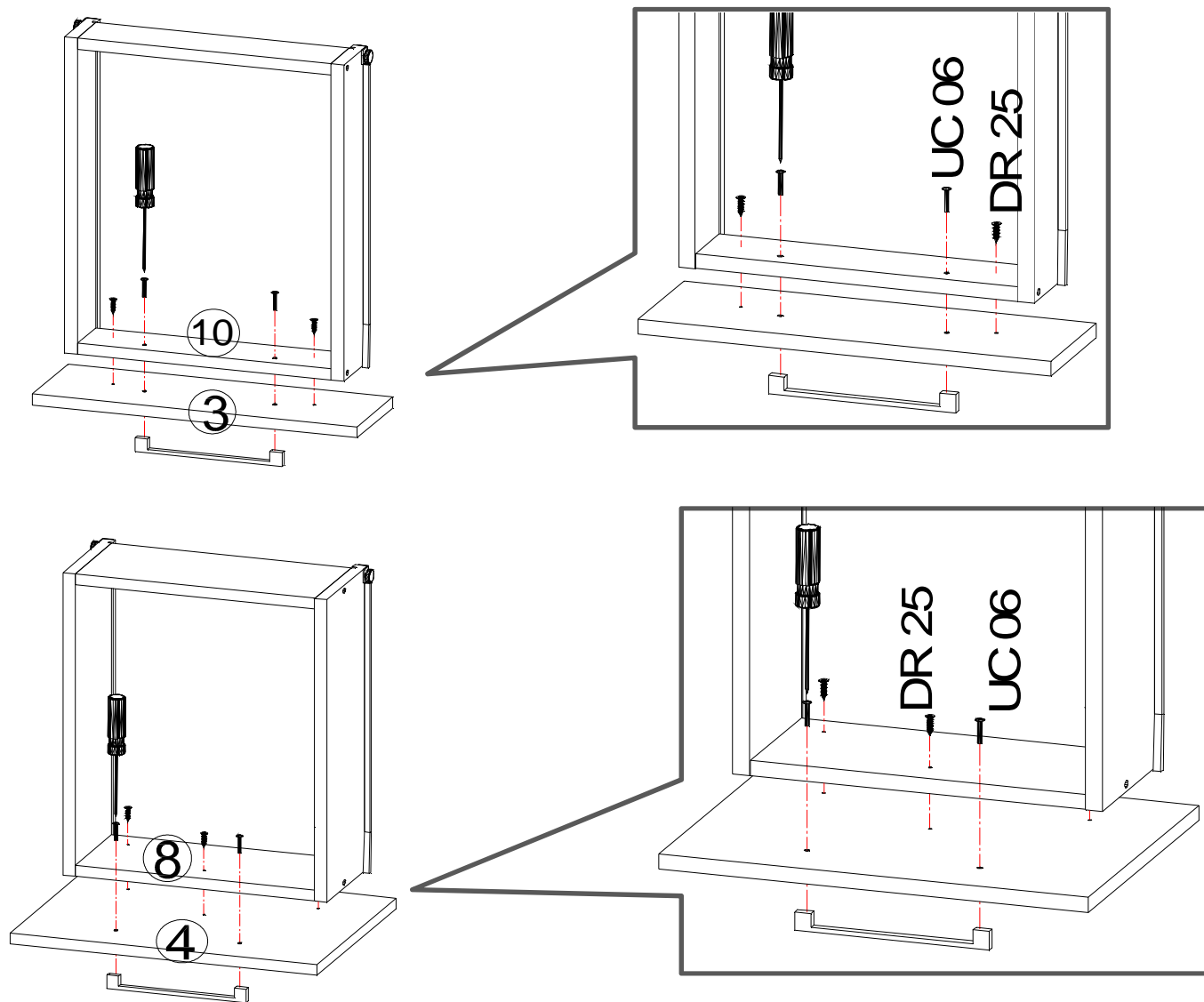

6.

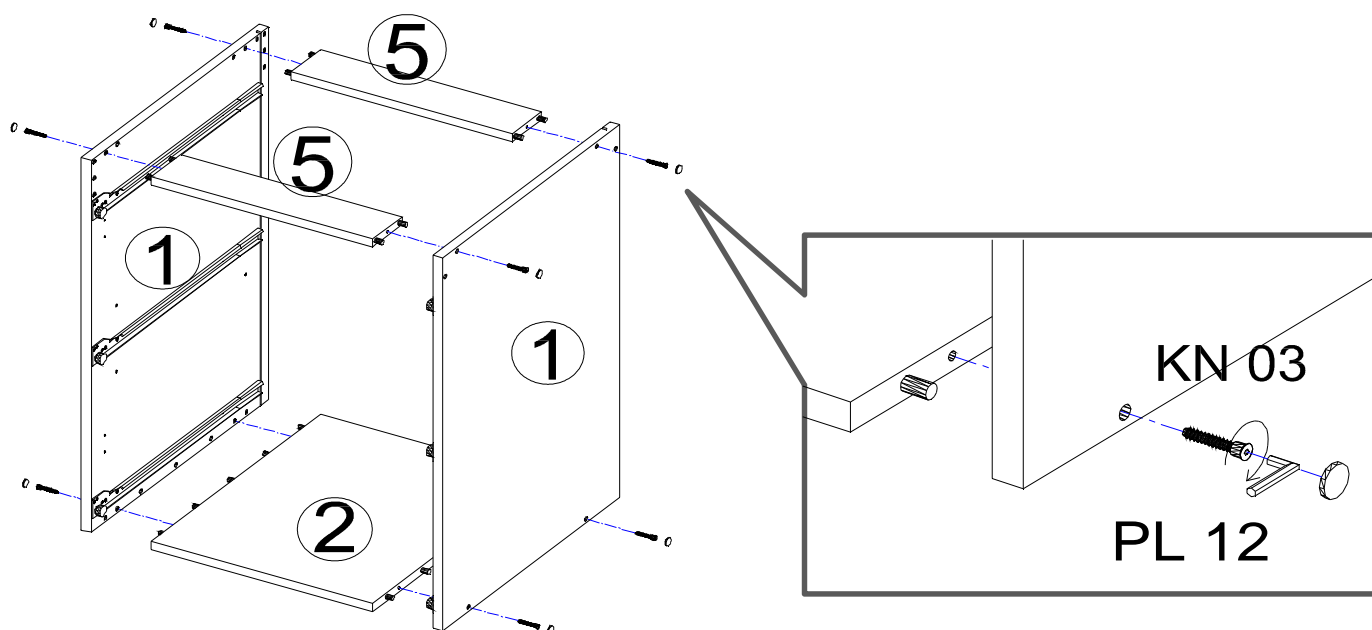

7.

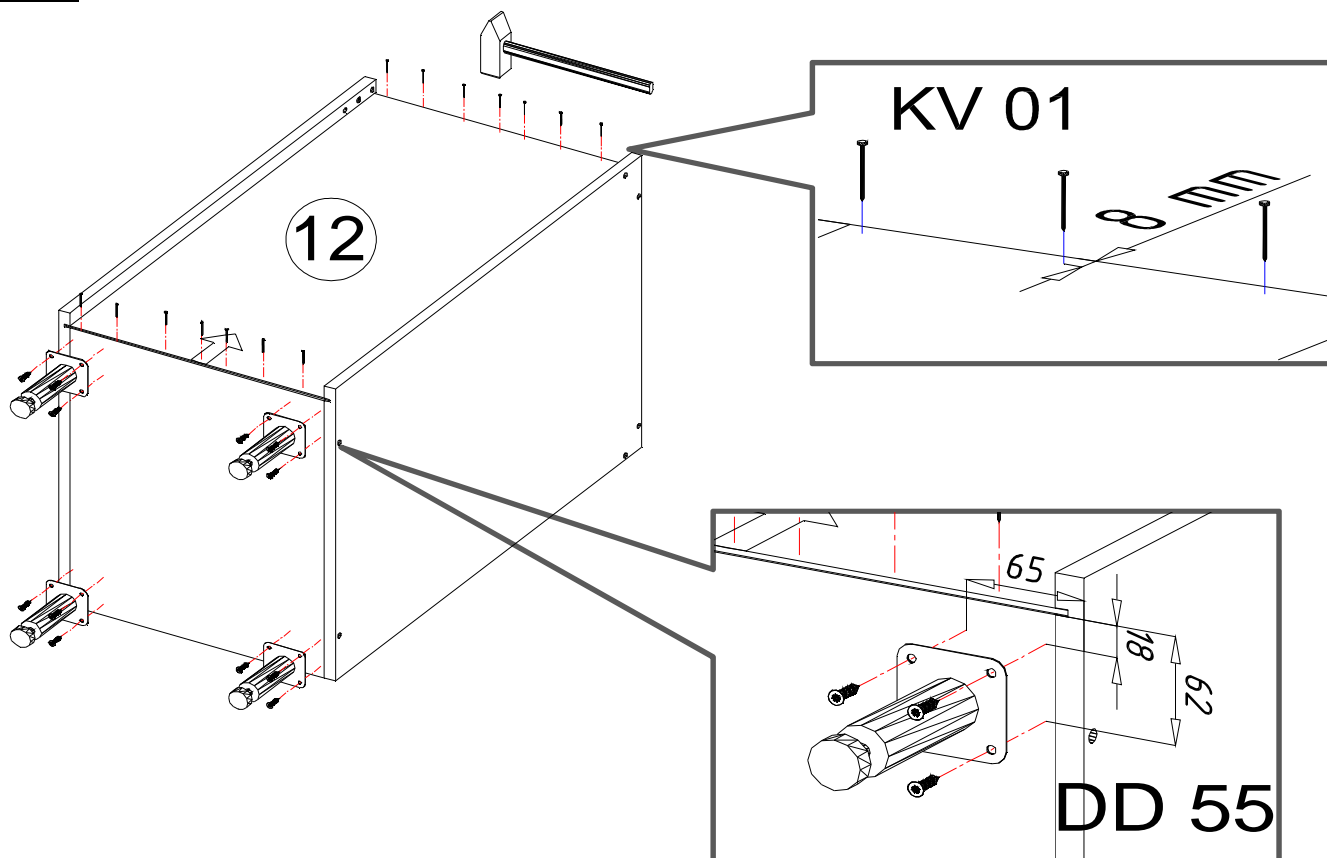

*Az elemek megfelelő stabilitása és baleset megelőzés céljából, az elemeket célszerű egymáshoz rögzíteni egy rejtett pozícióban a (DR 25 4*25) facsavarral!*