



Made for, Vyrobeno pro, Megrendelő, Vyrobené pre, Zrobiona przez,
Produs pentru, Proizvedeno za, Izdelano za

Roltechnik a.s.; Czech Republic, 56933 Třebov 160,
tel.: +420 461 324 301, fax: +420 461 324 297,
<http://www.roltechnik.cz>; e-mail: objednavky@roltechnik.cz

1. 2x



2. 2x

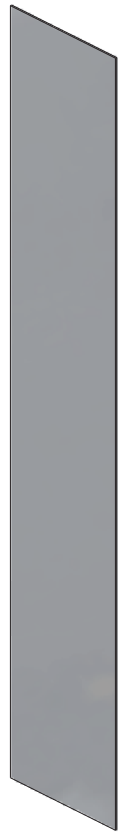

3. 2x



4. 2x



5. 2x

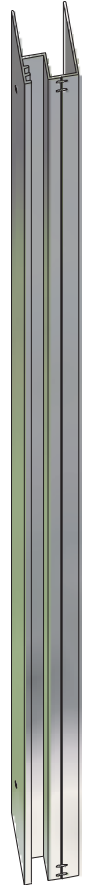

6. 2x

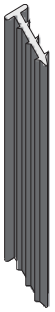

7. 4x



8. 2x

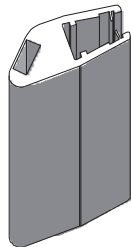

9. 4x

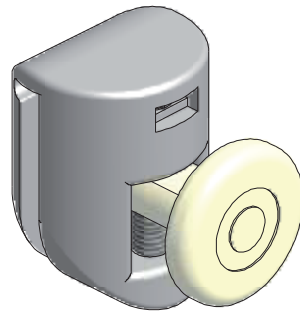

10. 4x

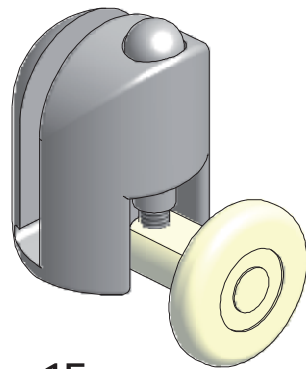

11. 16x



12. 8x

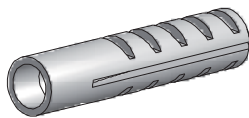

13. 6x



14. 6x



15. 6x



16. 2x

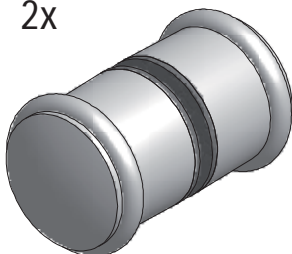

GB Beware! Before purchase check the product carefully for mechanical or other damage. No claims of this kind will be accepted after the installation.

- Shower enclosure (or hydromassage cabin) is possible to be installed only to the fully finished bathroom with installed tiles on the walls and with finished flooring.
- Product has to be moveable without any construction work.
- All contact areas are to be siliconized prior setting in operation.

CZ Pozor!!! - při koupi výrobku a před jeho instalací jej pečlivě překontrolujte, zda není mechanicky nebo jiným způsobem poškozen. Po instalaci již nebude brán ohled na poškození tohoto typu.

- Sprchový kout instalujte do předem stavebně připraveného prostoru. Tento kout musí být instalován do prostoru kompletně obloženého obklady a dlažbou.
- Výrobek musí být vyjímatelný bez násilných stavebních zásahů!!!
- Před uvedením koutu do provozu je nutné všechny styčné plochy řádně zasilikonovat.

H Figyelem!!! A termék megvásárlásakor ill. a beépítés előtt ellenőrizzük, hogy a termék mechanikailag nem károsodott. Az installálás után az ilyen típusú károsodásokért a gyártó sem a forgalmazó nem vállal felelősséget.

- A zuhanykabint építészeti szempontból előkészített térbe építsük be. Ezt a kabint olyan helységbe telepítsük, ahol a falak és padló is tökéletesen burkolt állapotban van.
- A terméket úgy kell beépíteni, hogy az bármikor kiemelhető legyen építészeti beavatkozások nélkül.
- Mielőtt a kabint üzembe helyeznénk, az összes érintkező felületet kenjük be szilikonnal

SK POZOR!!! - pri kúpe výrobku a pred jeho inštaláciou výrobok dôkladne prekontrolujte, či nie je mechanicky alebo iným spôsobom poškodený. Po nainštalovaní výrobku, v prípade poškodenia, už nebude uznaná reklamácia na výrobok.

- Sprchový kút inštalujte do vopred stavebne pripraveného priestoru. Tento kút musí byť inštalovaný do priestoru kompletne obloženého obkladmi a dlažbou.
- Výrobok musí byť vyberateľný bez násilných stavebných zásahov!!!
- Pred uvedením kúta do prevádzky je nutné všetky styčné plochy riadne zasilikónovať.

PL Uwaga! Przy zakupie produktu oraz przed jego instalacją należy dokładnie sprawdzić, czy nie został on mechanicznie lub w inny sposób uszkodzony. Po zainstalowaniu produktu tego typu, uszkodzenia nie będą uwzględniane.

- Kabiny prysznicowe (lub kabiny do hydromasażu) należy instalować w łazienkach w pełni wykończonych, muszą być wyłożone płytkami na ścianach i wykończoną posadzką.
- Produkt musi być zdolny do przemieszczeń bez wykonywania jakichkolwiek prac budowlanych.
- Do niewypełnionych przestrzeni należy użyć silikonu.

RO Atentie! Inaintea achizitionarii verificati produsul cu atentie sa nu aiba defecte mecanice sau de alt fel. Nicio reclamatie nu va fi acceptata daca aceasta va fi facuta dupa instalare.

- Cabina de dus (sau Cabina cu hidromasaj) se poate instala doar intr- baie cu faianta si gresie deja montata.
- Produsul trebuie sa fie demontabila fara nicio lucrare de constructie in prealabil.
- Toate zonele de contact trebuie siliconizate inainte de punerea in operatie.

HR Pažnja!!! - proizvod pažljivo prekontrolirajte prilikom kupovine, te prijete njegove instalacije da ne bi bio oštećen mehanički ili nekako drugačije. Nakon instaliranja više se neće uzimati u obzir oštećenja ovog tipa.

- Kabinu za tuširanje instalirajte u prostor koji je građevinski unaprijed pripremljen. Ova kabina mora se instalirati u prostor koji je u potpunosti obložen podnim i zidnim pločicama.
- Proizvod mora biti moguće izvaditi bez nasilnih građevinskih intervencija!!!
- Prije upotrebe tuša potrebno je sve dodirne površine dobro osigurati silikonom.

SL POZOR! OB NAKUPU IN PRED MONTAŽO IZDELKA PREVERITE, DA BLAGO NI MEHANSKO POŠKODOVANO. PO MONTAŽI NE MOREMO PRIZNATI REKLAMACIJE MEHANSKIH POŠKODB .

- Kabino za prhanje namestite v vnaprej gradbeno pripravljen prostor. Kabino je treba namestiti v prostor, ki je kompletno opremljen z oblogo in s ploščicami.
- Pred uporabo kabine je treba s silikonom temeljito zatesniti vse stične ploskve ter priviti vse spoje razdelilnih cevi.
- Preden vstavite kabino v ogradni prostor, je treba pregledati tesnost vseh razdelilnih cevi.

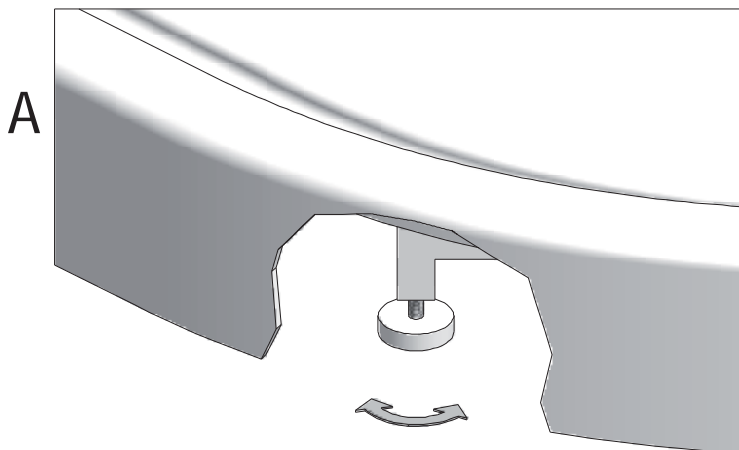
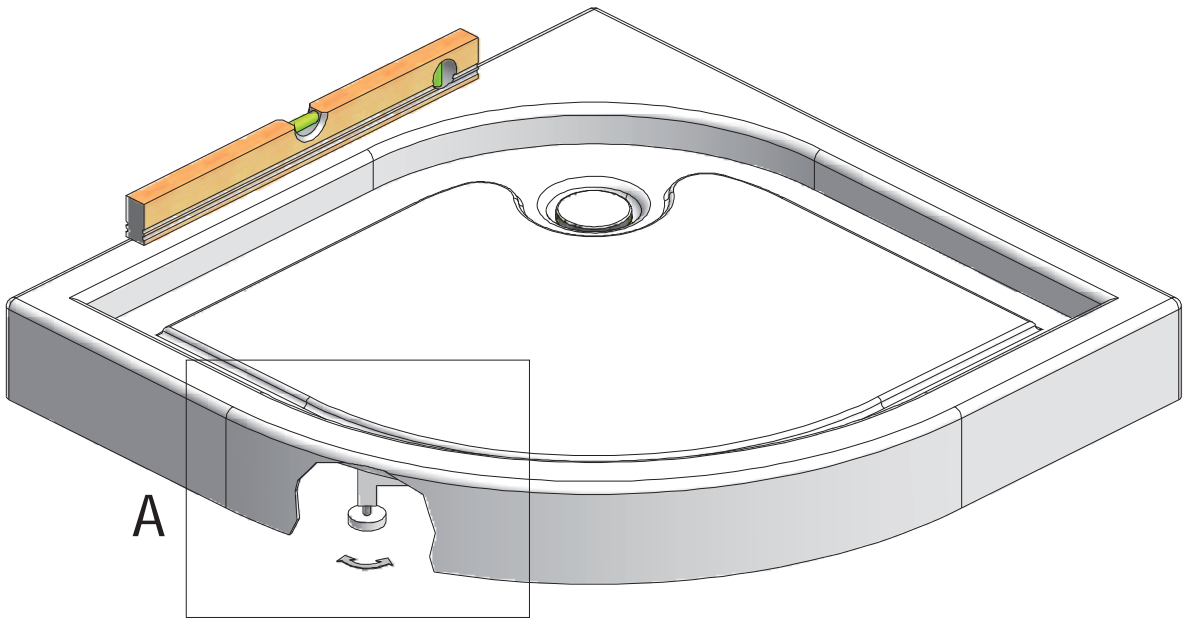
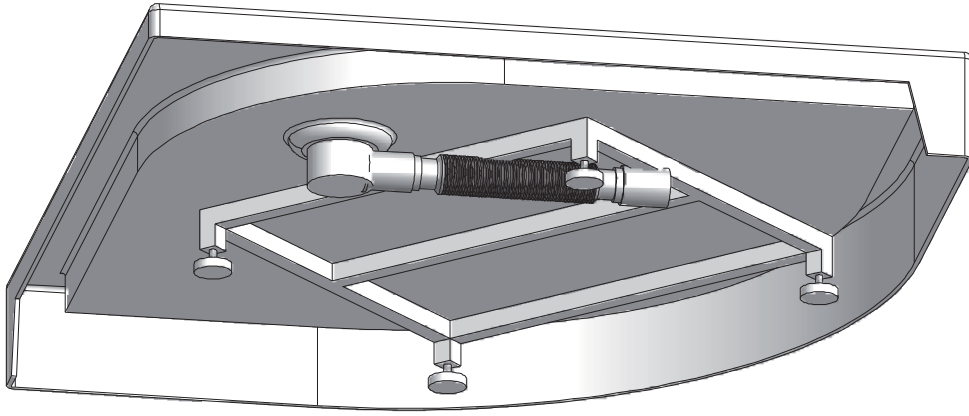

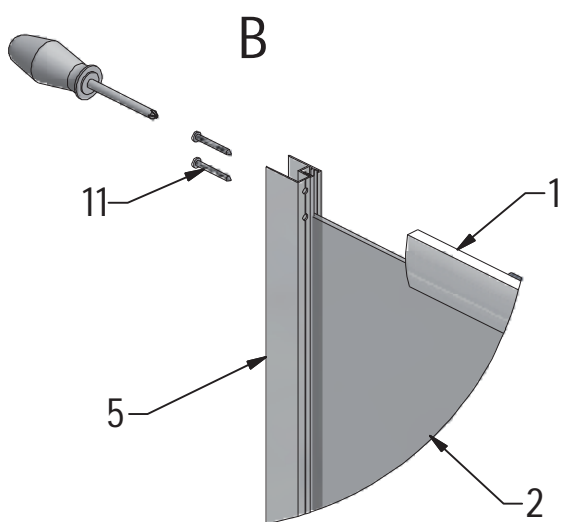
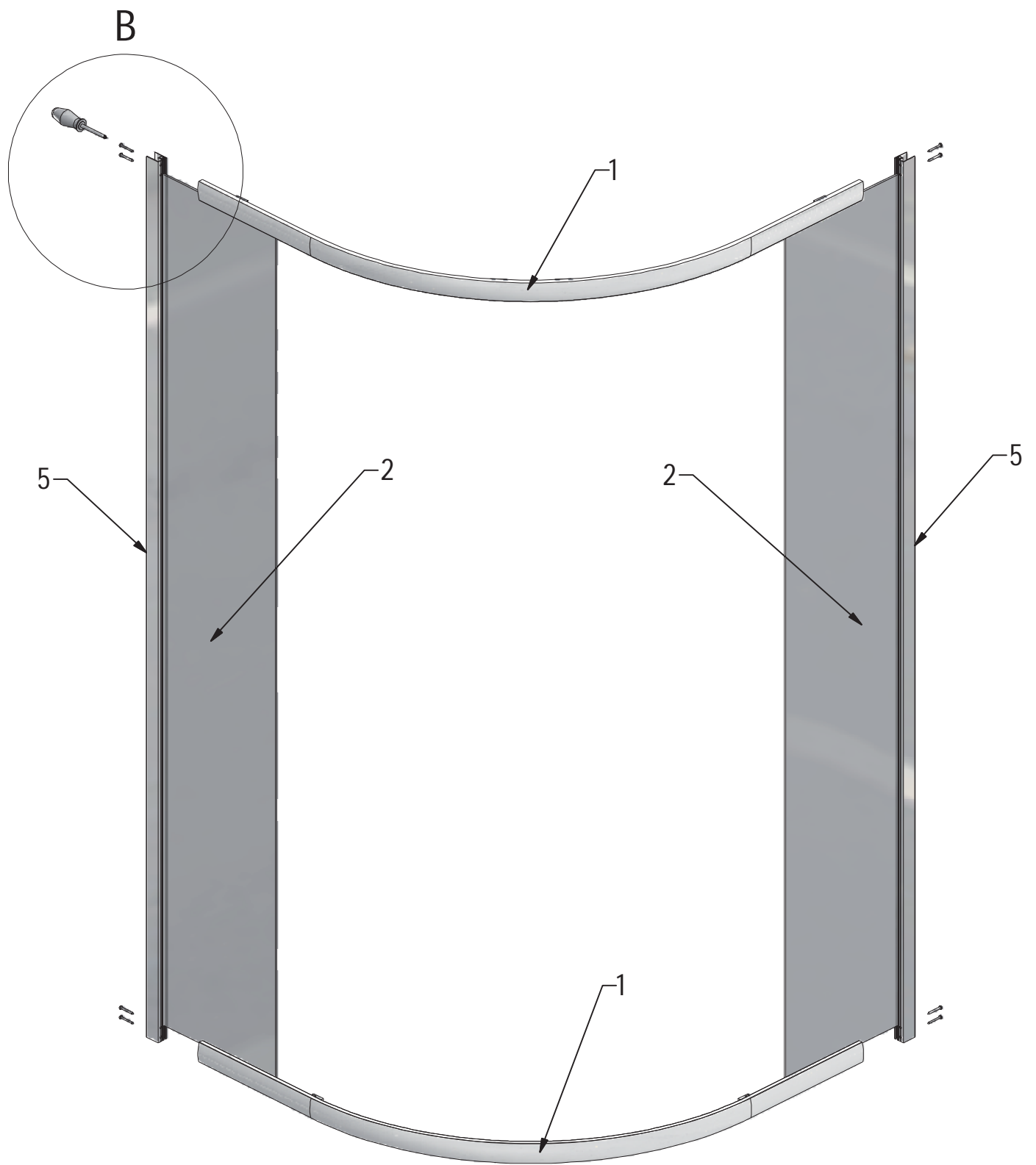

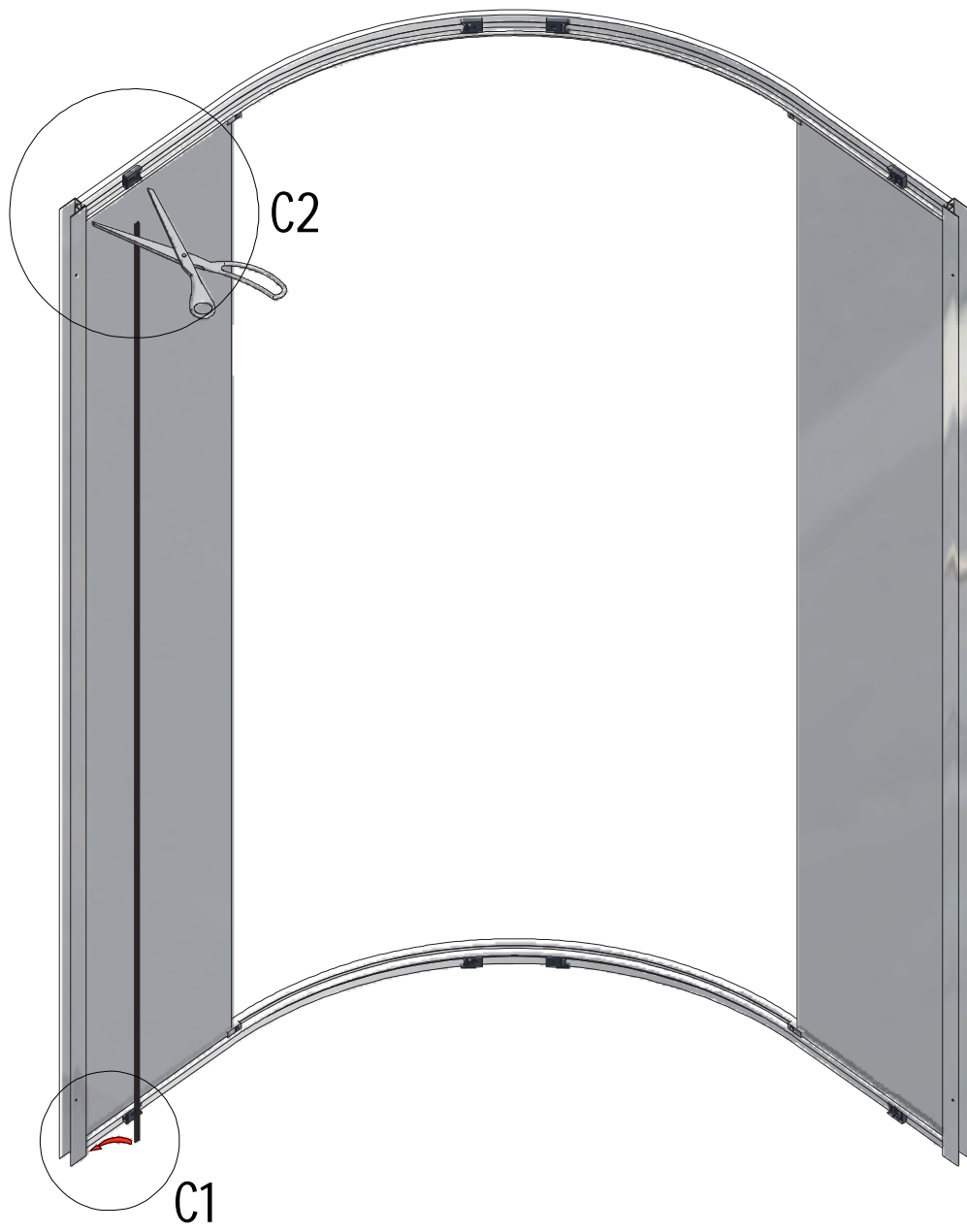

C1

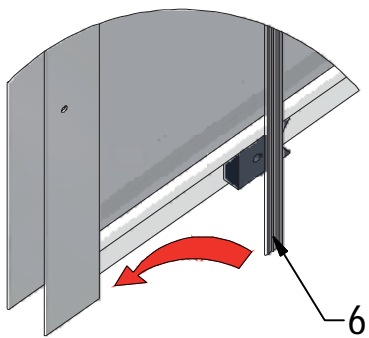

C2

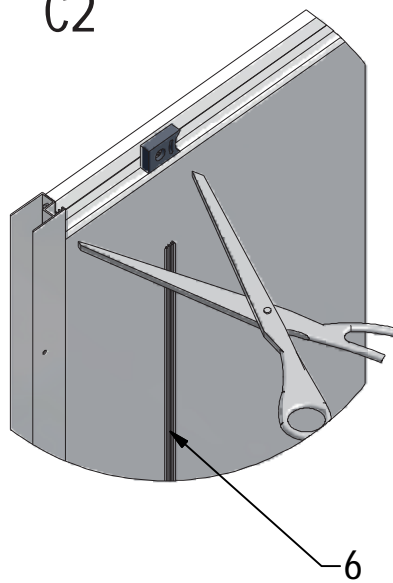

C3

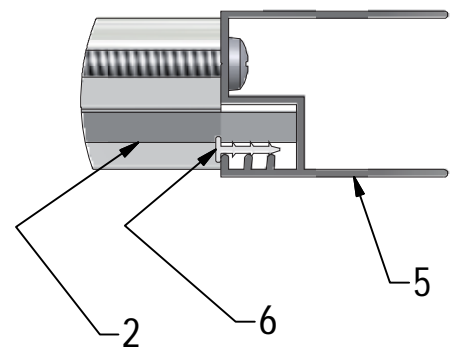

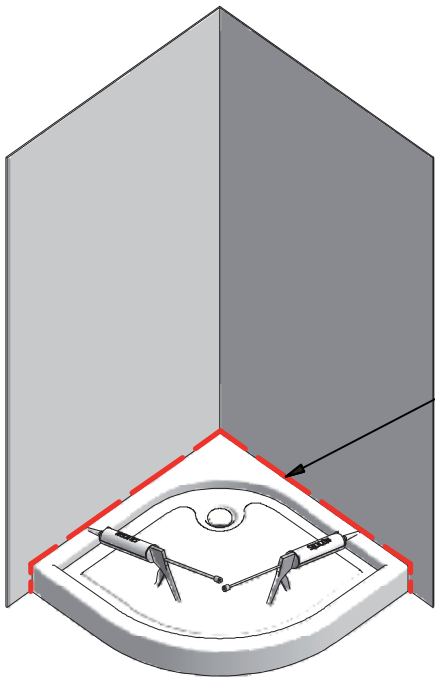

SILICON

4

4

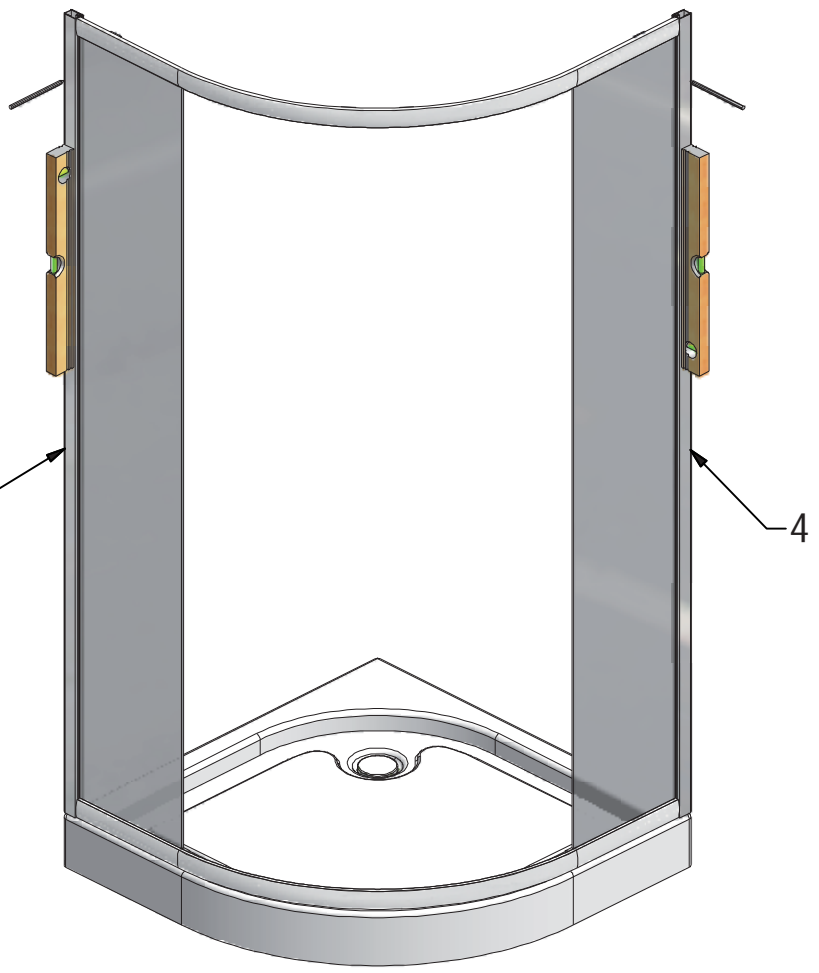

8x

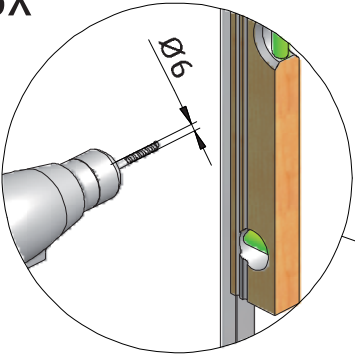

8x

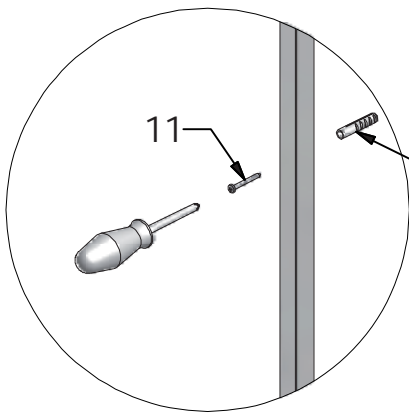

4

4

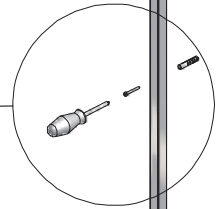
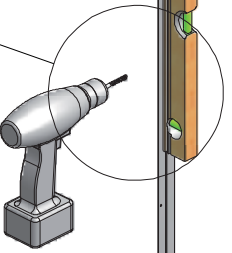
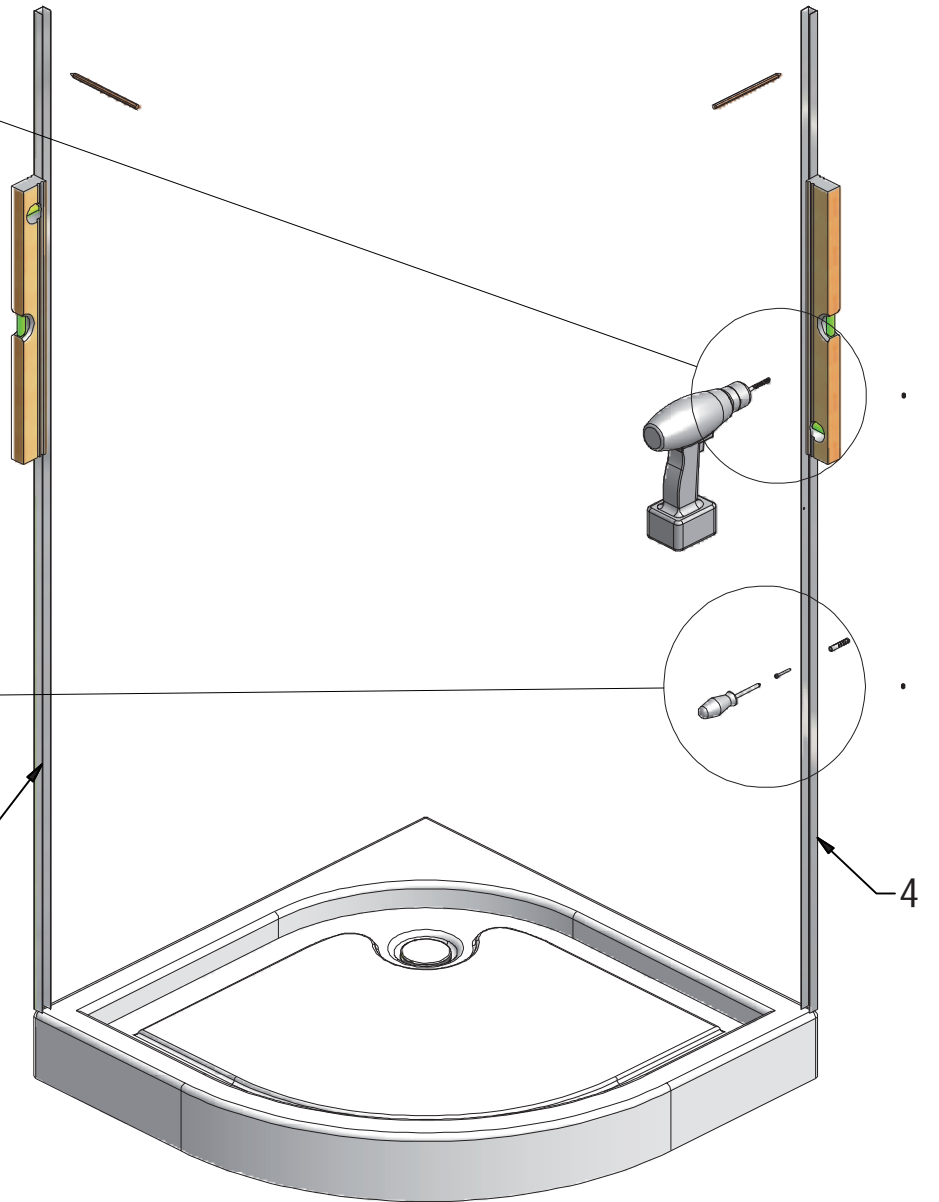

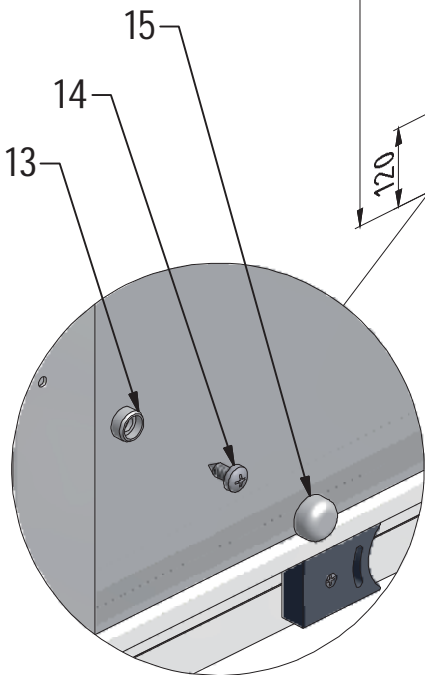
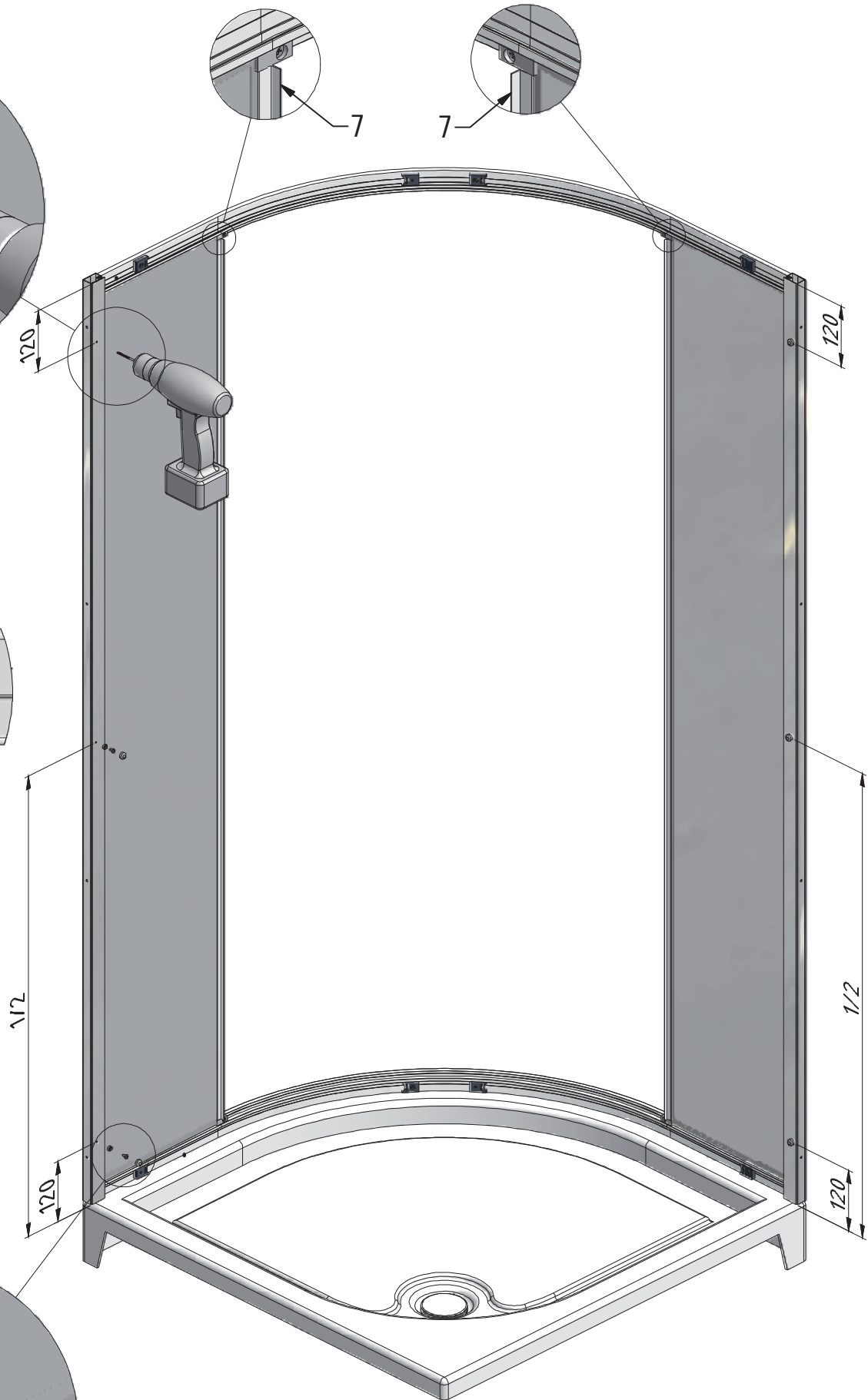
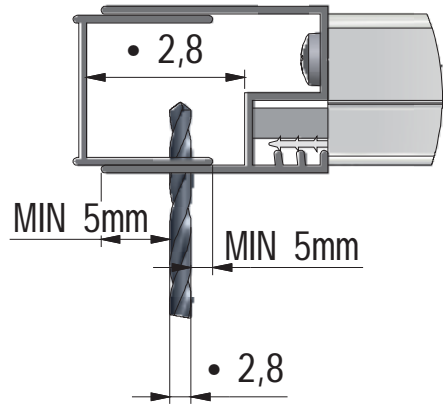
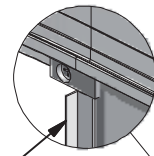
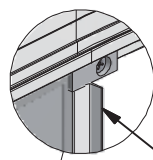
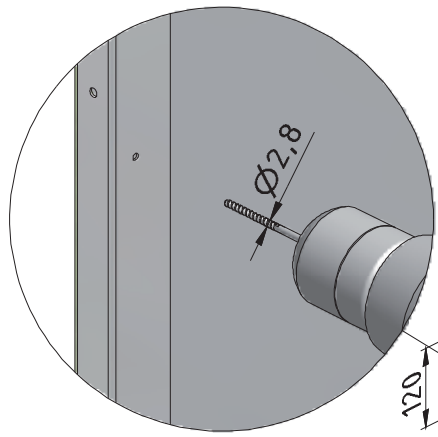

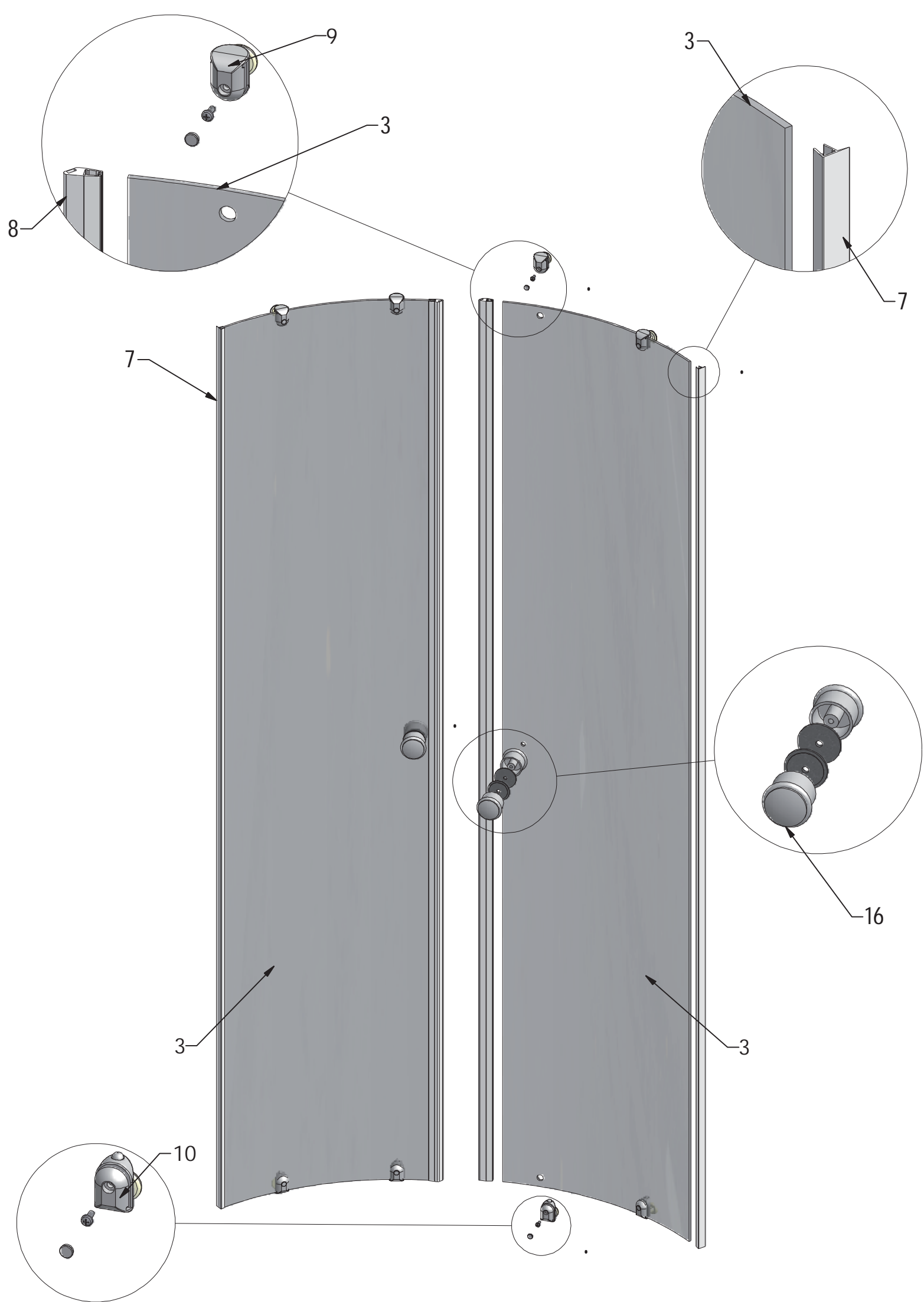

D1

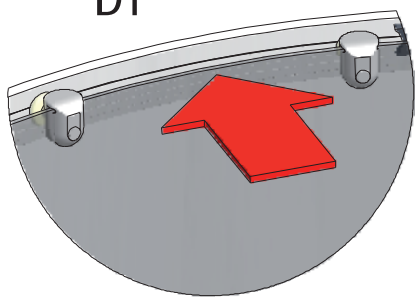

D1



D2

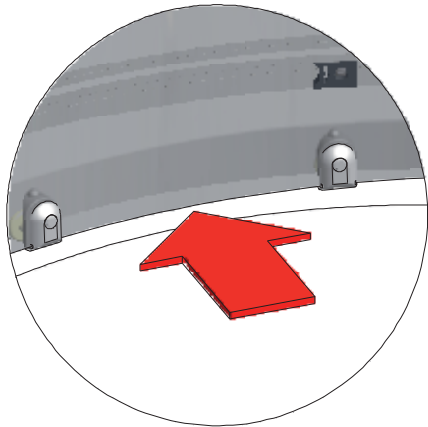

D3

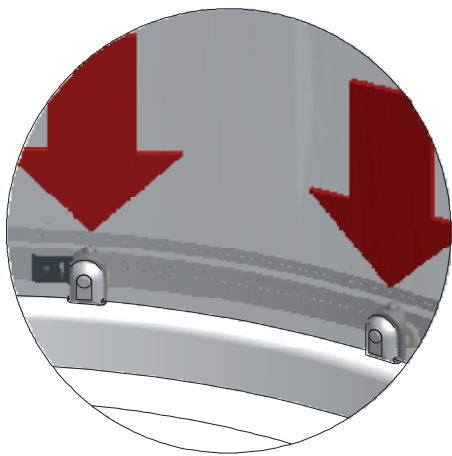

D4

