

# 1. Oszlopközök kialakítása

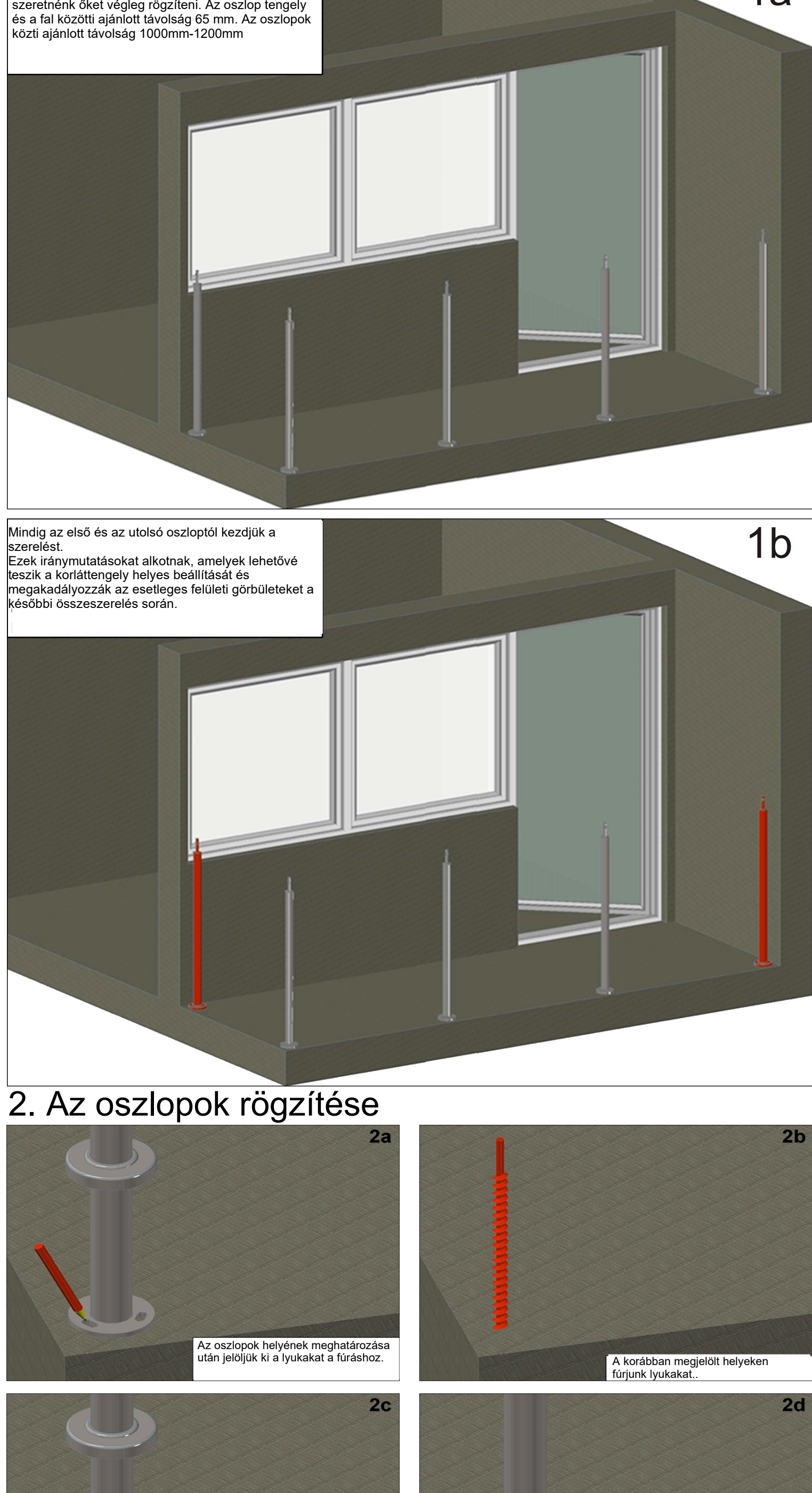

# 2. Az oszlopok rögzítése

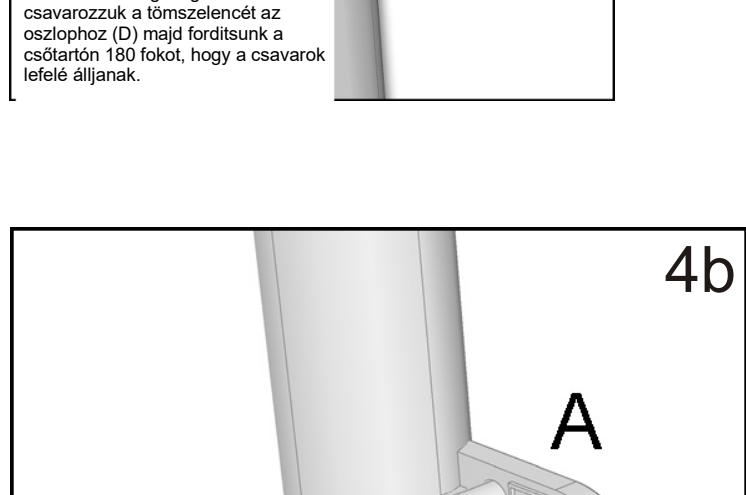
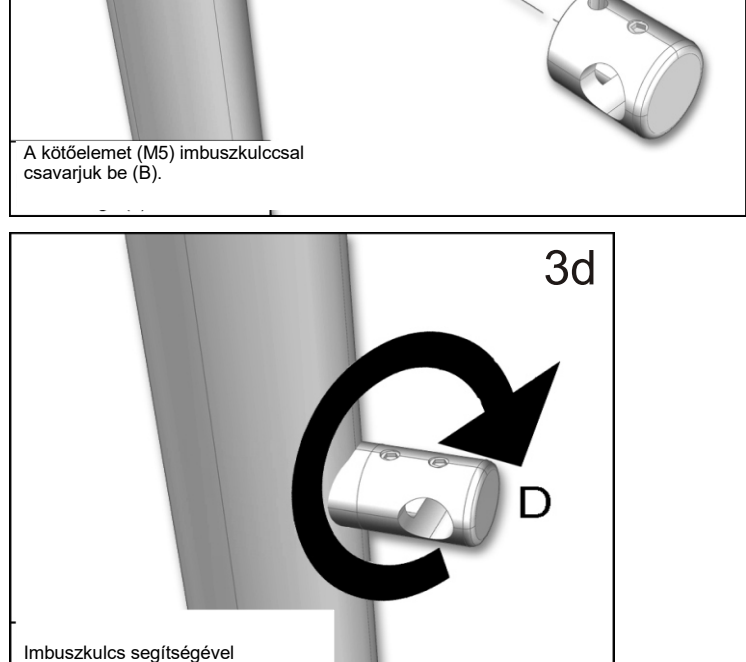
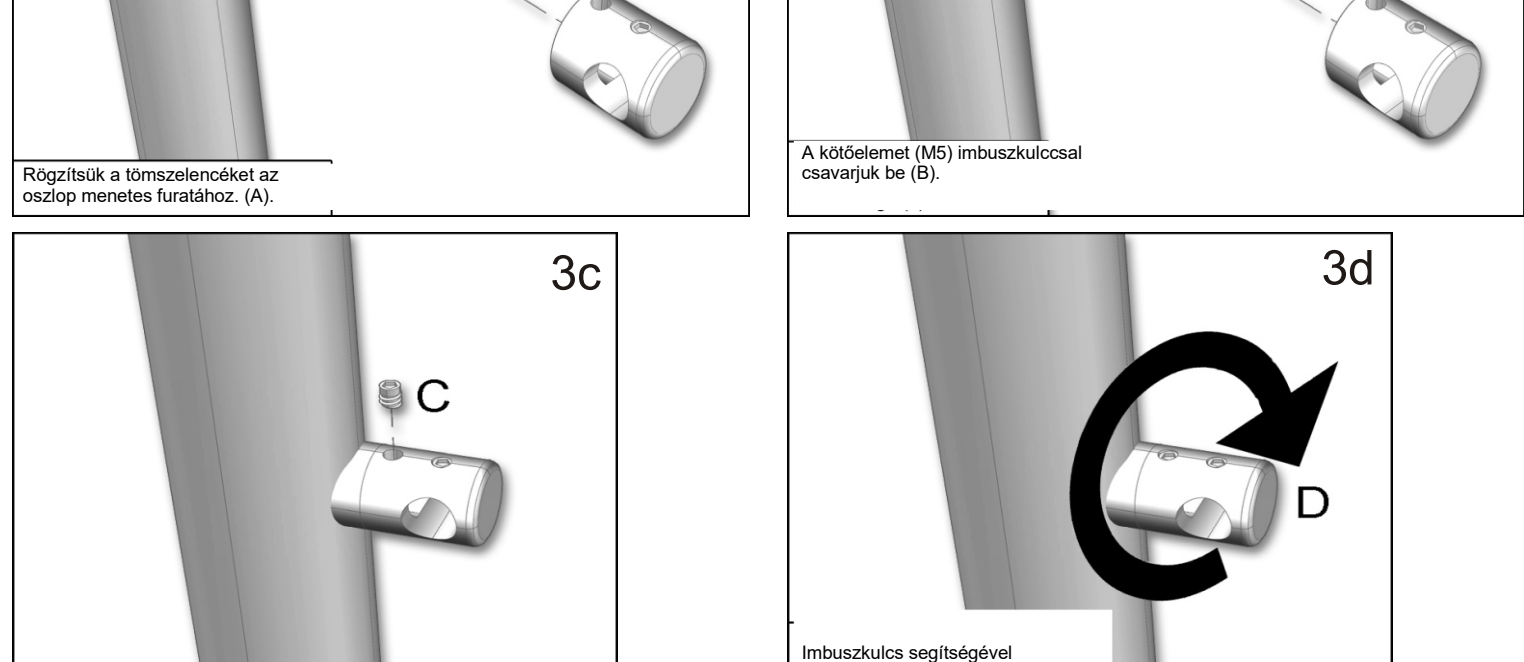

# 3. A csőtartó / tömszelence rögzítése

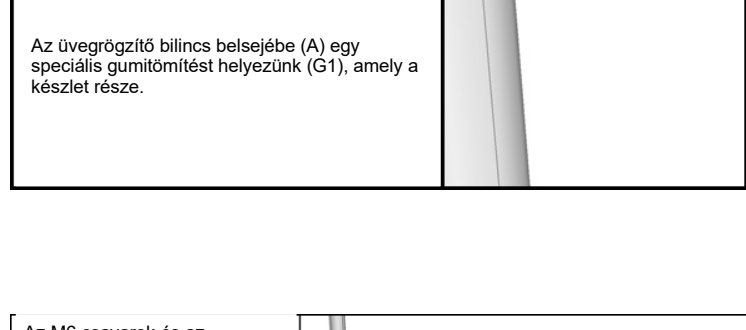
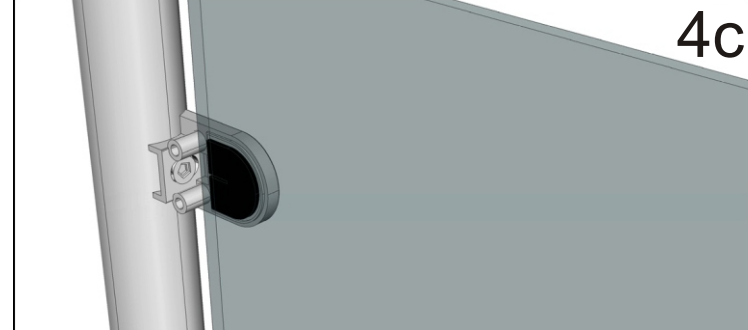
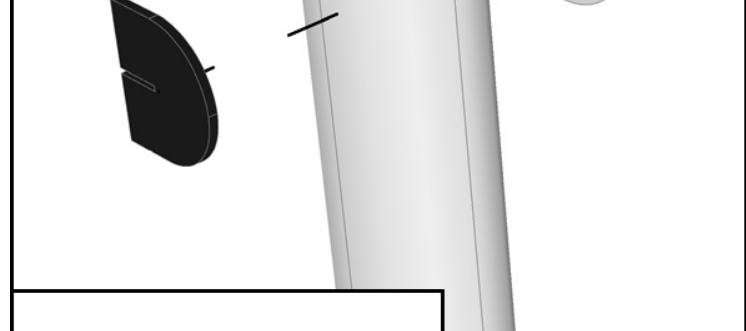
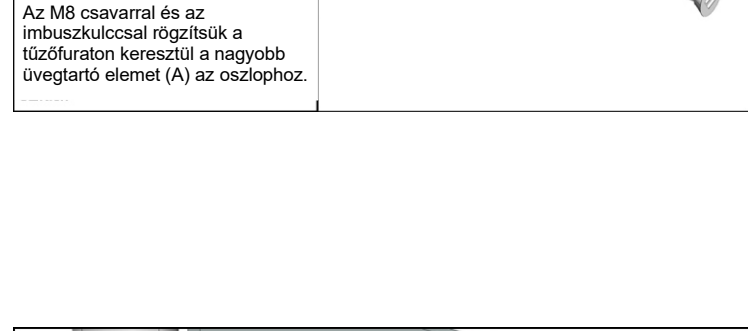

# 4. Üvegtartó rögzítése

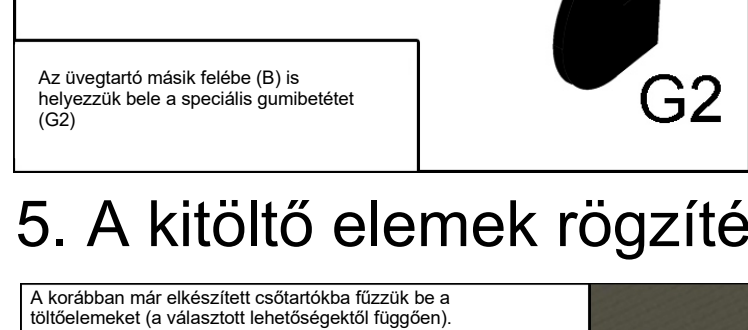
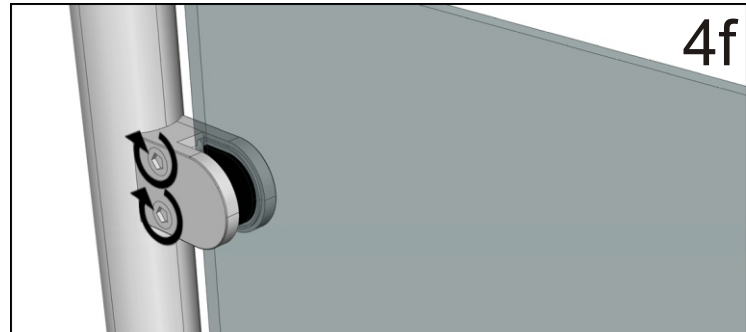
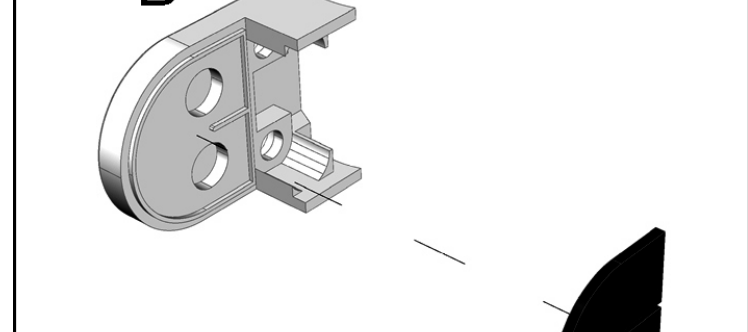
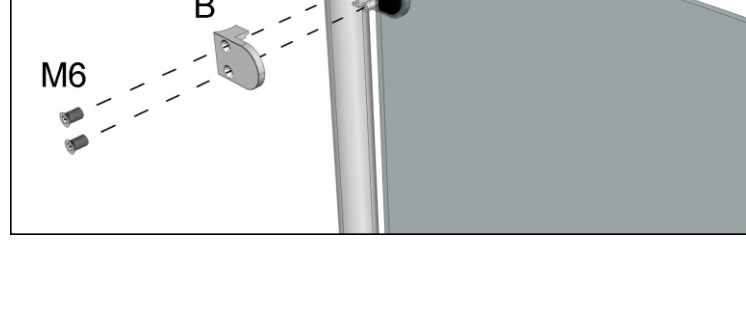
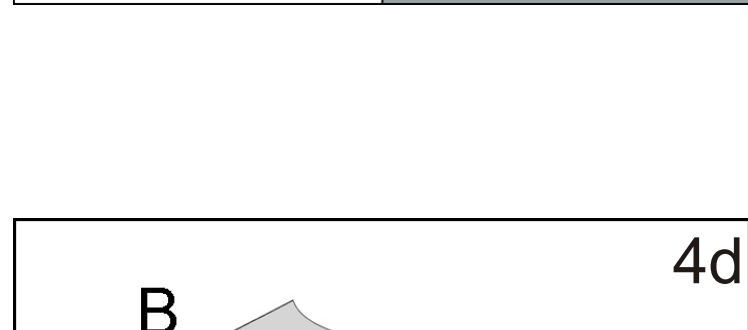

# 5. A kitöltő elemek rögzítése

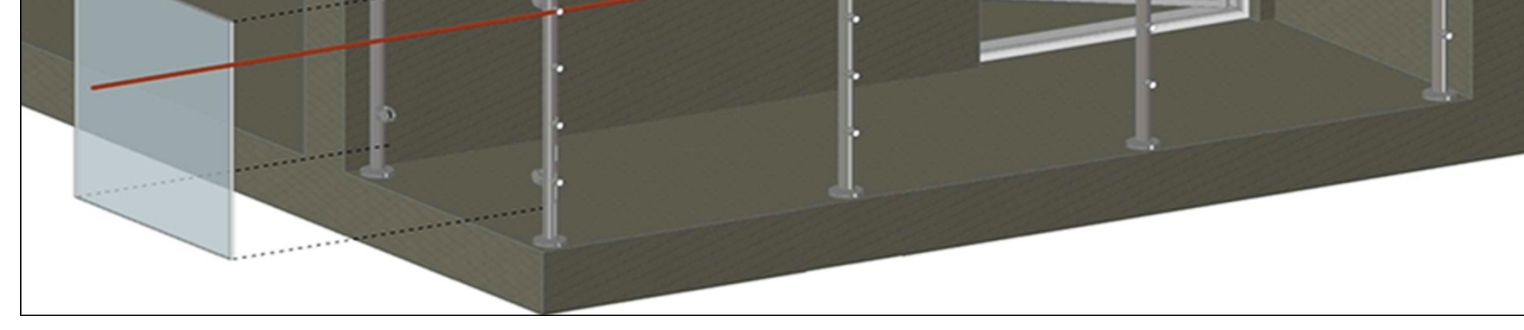

# 6. Cső/rúd csatlakozó

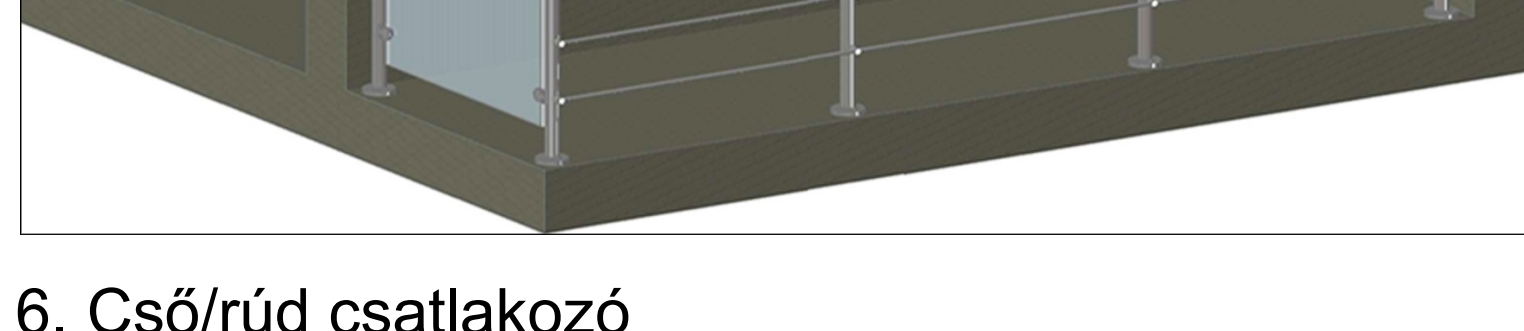
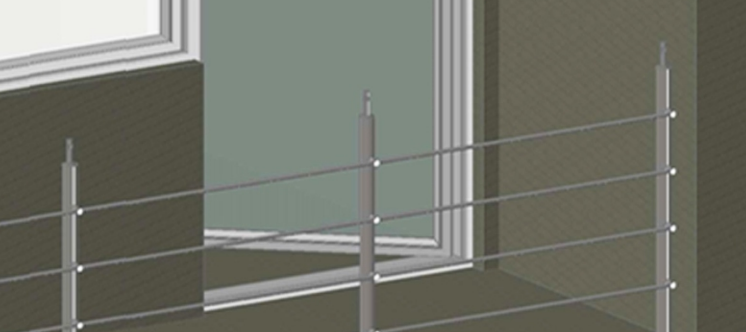
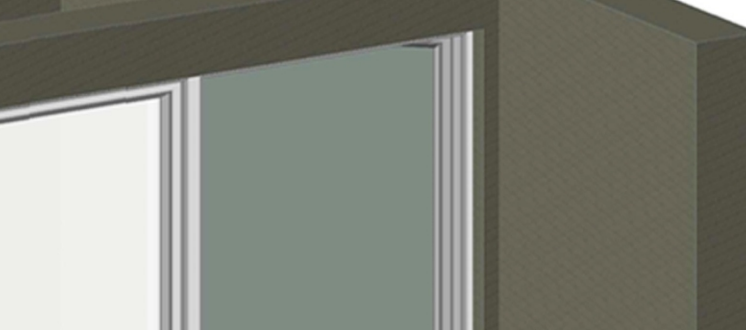

# 7. Kapaszkodó korlát tartó rögzítése

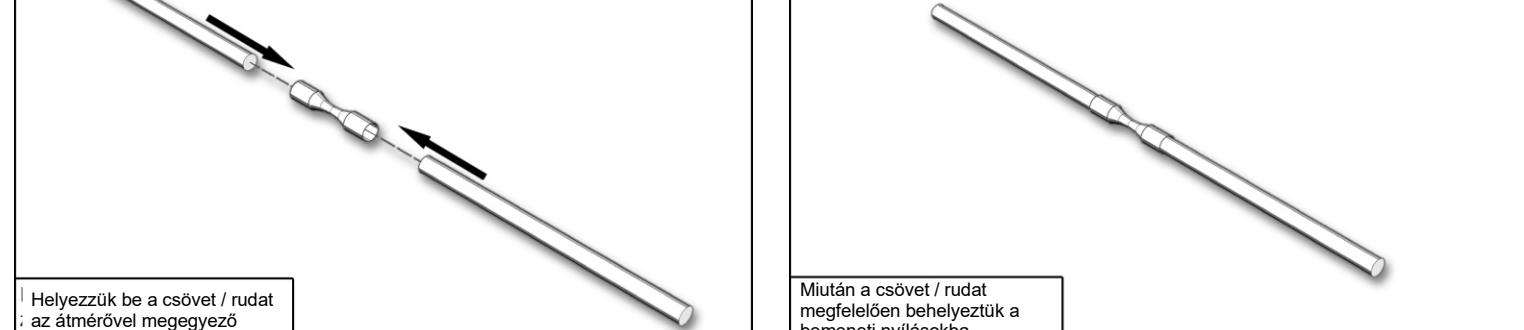

# 8. A kapaszkodó korlátok csatlakoztatása

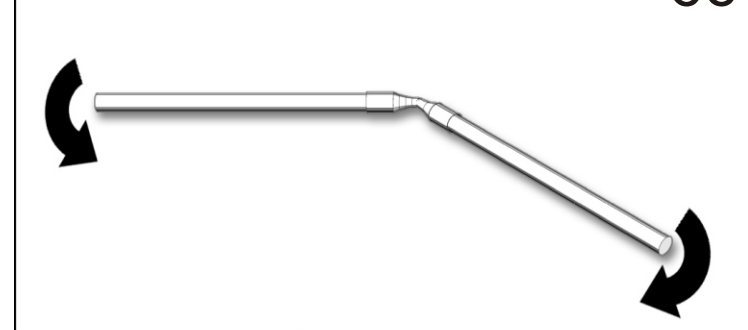

# 9. Kapaszkodó korlátok felszerelése

